

**Black
is back.**

MADE IN ITALY

PRODOTTO IN ITALIA

FABRIQUE EN ITALIE

FABBRICADO EN ITALIA

Indice

contents

Introduzione

Introduction

Flow Pure

meccanismo a rotazione / twist-action

F2 P – GOM K **NEW**
F2 P – GOM CB **NEW**
F2 P – GOM 30 **NEW**
F2 P – GOM CF **NEW**
F2 P – GOM KF **NEW**
F2 P – GOM 30 F **NEW**

Flow

meccanismo a rotazione / twist-action

F1 – BC CR
F1 – B 30 CR
F1 – C CR
F1 – 30 CR
F1 T – GOM C CR
F1 T – GOM CB CR
F1 T – GOM 30 CR

Dot

meccanismo a scatto / retractable

D1 – B CR
D1 – BC CR
D1 – B 30 CR
D1 – CB CR **NEW**
D1 – C CR
D1 – 30 CR
D1 – GOM CB CR **NEW**
D1 – GOM C CR
D1 – GOM 30 CR
D1 – C GOLD **NEW**
D1 – GOM CB F CR **NEW**
D1 – GOM KF CR **NEW**
D1 – GOM 30 F CR **NEW**

Zink

meccanismo a rotazione / twist-action

Z1 – C
Z1 – B 30
Z1 – 30
Z1 – CF **NEW**

View

meccanismo a rotazione / twist-action

V1 – C CR
V1 – 30 CR
V1 – AL CR
V1 – GOM C CR T
V1 – GOM C CR

Tag

meccanismo a rotazione / twist-action

TA1 – MATT AL B

06 TA1 – B CR
TA1 – CB CR
TA1 – MATT AL
10 TA1 – FROST AL
TA1 – C CR
14 TA1 – 30 CR
16 TA1 – GOM C CR
18 TA1 – MET AL
20 TA1 – AL CR
21
22

Icon

meccanismo a rotazione / twist-action

26 IC400 – C
IC400 – MATT
30 IC400 – 30
32 IC400 – FROST
34 IC400 – MATT AL
36 IC400 – C CR
38 IC400 – FROST AL
40 IC400 – 30 CR
42 IC400 – C GOLD
IC400 – MET AL
IC400 – AL CR

Tag green

meccanismo a rotazione / twist-action

48 TA2 – B
50 TA2 – BC
54
56

Icon green

meccanismo a rotazione / twist-action

60 IG2 – BC
62 IG2 – C
64
66

Ethic

meccanismo a rotazione / twist-action

67 ET900 – MULTICOLOUR
68 ET900 – FLAG
69 ET900 – C FLAG
70 ET900 – B
74 ET900 – BC
76 ET900 – C CR
78 ET900 – C GOLD
82 ET900 – AL
ET900 – AL CR
ET900 – AL FLAG
84 ET900 – MET CR
ET900 – MET AL
88
90

Next

meccanismo a scatto / retractable

91 NX400 – C CR
92 NX400 – 30 CR
94 NX400 – FROST AL
96 NX400 – MET AL
100 NX400 – AL CR

102 NX400 – GOM C CR 168
103 NX400 – GOM AL 169
104

Pixel

meccanismo a scatto / retractable

105 **170**
106
108 PX40 – B 174
109 PX40 – C 175
110 PX40 – MATT CR **NEW** 176
111 PX40 – B 30 178
PX40 – 30 179
112 PX40 – FROST NEUTRAL 180
PX40 – FROST 181
116 PX40 – GOM C CR 182
117 PX40 – GOM 30 CR 183
118

Bay

meccanismo a rotazione / twist-action

119 **186**
120
122 B500 – MATT BC **NEW** 190
124 B500 – MATT 192
125 B500 – BC 194
126 B500 – C 195
127 B500 – 30 196
127 B500 – FROST 197

Soft

meccanismo a rotazione / twist-action

128 **198**
134 S90 – B 202
135 S90 – B 30 203
S90 – 30 204
136 S90 – AL 30 205

Polo

meccanismo a scatto / retractable

142 P600 – B 210
143 P600 – C 211
P600 – C AL 212
P600 – 30 AL 213

Servizi

Services

151 minikit fluo **NEW** 218
152 fluo minikit
153

154 supporti di vendita 220
155 sales support
156

157 palette colori 222
157 colour palette
158

159 palette colori 222
160 colour palette
164 codici pantone 223
165 pantone codes

166 inchiostri e refill 224
167 inks and refills
167

Qualità

in ogni dettaglio
Quality in every detail



/ 06



IT In un mondo oberato di incertezze e sovrapproduzione, il bello e la qualità restano un porto sicuro in cui rifugiarsi. Da sempre i nostri valori di riferimento sono l'eleganza dei modelli e la ricerca qualitativa dei materiali. Oggi, ancora di più, crediamo sia necessario realizzare prodotti che abbiano un valore oggettivo: che durino nel tempo e non siano nocivi, che siano attraenti e sappiano catturare le emozioni non solo in virtù di mode passeggere, bensì di canoni estetici tangibili. Il consumo responsabile è una visione globale che abbraccia ogni settore produttivo e noi cerchiamo di promuoverlo con entusiasmo. Le nostre penne sono realizzate con plastiche atossiche e materiali di prima qualità certificata, pensate per durare nel tempo, e valorizzare al massimo l'obiettivo commerciale del cliente. Produciamo nel rispetto dell'ambiente e di chi scriverà con le nostre penne: questa è la nostra visione per un futuro di crescita responsabile.

EN In a world fraught with uncertainty and overproduction, beauty and quality continue to be a safe haven where to take refuge. Elegant model design and the selection of top quality materials have always been the values we adhere to. And today more than ever we deem it essential to create products that have an objective value in themselves, that will last long and that are not harmful, products that are attractive and are able to appeal to the emotions not only on the basis of passing vogues but rather on the basis of tangible aesthetic principles. Responsible consumption is a global vision encompassing all production sectors, and we are firmly committed to promoting this approach with enthusiasm. Made from non-toxic plastic and certified quality materials, our pens are designed to last over time and to help our customers attain their sales objectives. Our product processes reflect our care for the environment and the people who will write with our pens: this is our view for a future of responsible growth.

/ 07

Maxema

solo una penna?
Maxema, just a pen?



Progettazione

Planning

IT Non tutti sanno che per costruire una penna curata in ogni dettaglio può essere necessario anche più di un anno di lavoro. Costruire lo stampo per ogni componente di una penna è un'operazione molto complessa: anche l'errore di un centesimo di millimetro può comprometterne la funzionalità. Ecco perché la progettazione e la produzione delle nostre penne avviene interamente nella nostra unica sede italiana, dove possiamo controllare ogni passaggio: dai primi prototipi fino alla commercializzazione del prodotto definitivo.

EN Not everyone knows that it can take more than a year to create a new pen in which every detail is handled with meticulous care. Creating the moulds for each component of the pen is a highly complex operation: a mistake of even a hundredth of a millimetre could jeopardise its operation. This is why all our pens are designed and manufactured entirely in our only Italian premises, where we are able to monitor every stage: from the first prototypes right down to marketing the finished product.

Design

Design

IT Il design delle nostre penne è frutto di costanti ricerche stilistiche: le linee e i colori si ispirano alle tendenze del momento. Una penna promozionale deve attrarre ed emozionare, oltre che essere un supporto di qualità per il messaggio che le viene affidato. Estetica, originalità, qualità: tutto deve essere perfettamente equilibrato per rendere una penna degna di sposarsi ad un'immagine aziendale unica e speciale.

EN The design of our pens is the outcome of ongoing styling research: the lines and colours are inspired by the trends of the day. A promotional pen must attract and excite, as well as being a quality support for the message it is delegated to convey. Appearance, originality, quality: everything must be perfectly balanced to make a pen worthy to carry a uniquely special company image.

Qualità

Quality

IT La cura della qualità comincia dalla severa selezione delle materie prime: la plastica, i refill e le molle interne provengono esclusivamente da fornitori italiani o tedeschi, che possono garantirne la qualità e l'affidabilità. La plastica è ottenuta con ABS di prima qualità, atossico, altamente resistente ad urti e sbalzi termici, garanzia di eccellente lucentezza e stabilità del colore. I refill sono conformi alle Direttive della Comunità Europea in materia di sostanze pericolose (2004/73/EC, 67/548/EEC, 2006/1907/EC-REACH) e al TSCA (Toxic Substances Control Act) americano, in quanto contengono inchiostri atossici.

EN Attention to quality starts with the strict selection of raw materials: the plastic, refills and inner springs come exclusively from Italian or German suppliers, who guarantee their quality and reliability. The plastic for our pens comes from top quality, non-toxic ABS, which is highly resistant to knocks and sudden changes in temperature, guaranteeing excellent glossiness and high colour stability. The refills respect EU Directives for hazardous substances (2004/73/EC, 67/548/EEC and 2006/1907/EC-REACH) and the American TSCA (Toxic Substances Control Act): so all the inks are non-toxic.

Sostenibilità

Sustainability

IT Solo una penna di qualità valorizza ogni messaggio, aumenta la visibilità di un marchio e contribuisce a limitare l'inquinamento del pianeta. La plastica inquina: se una penna è di qualità, avrà una vita mediamente lunga che la porterà a passare più volte di mano in mano, contenendo gli sprechi che derivano dall'immediata eliminazione di penne difettose. Meglio investire in penne di qualità, magari riducendone la quantità, piuttosto che rischiare di compromettere la propria immagine e diffondere un uso poco responsabile delle penne in plastica. Più lunga è la vita di una penna, meno si inquina l'ambiente.

EN Only a quality pen can really enhance a message, growing a brand's visibility and, why not, helping to limit the pollution of the planet. Plastics pollute: if a pen is high quality it will have a long average lifespan that will lead it to change hands more than once, so limiting the waste that comes from the immediate discarding of faulty pens. It is much better to invest in quality pens, maybe choosing to limit the quantity rather than running the risk of compromising your image and spreading the irresponsible use of plastic pens. The longer a pen's life is, the less it pollutes the environment.

Personalizzazione

Customisation

IT Una volta montata, la penna è pronta per essere "vestita" con un marchio o un messaggio: il nostro studio grafico elabora simulazioni digitali per valutare le possibili alternative e suggerisce nuove proposte per arrivare all'abbinamento più adatto. Proprio come in una sartoria si provano misure, colori e posizioni diverse finché l'abito si adatta perfettamente alle forme del cliente. Solo allora comincia la fase di stampa, tampografica o serigrafica, che avviene con l'utilizzo di vernici ad alta tenuta, al termine della quale la penna è finalmente pronta per portare il suo messaggio prezioso: la vostra immagine.

EN Once assembled, the pen is ready to be "dressed" with a logo or a message: our graphics office works on digital simulations to assess the possible alternatives, suggesting new proposals so that the most suitable combination can be found. Like a tailor's shop, the customer can try different sizes, colours and positions until the suit adapts perfectly to his needs. Only then does the pad or silk-screen printing stage begin, using highly resistant paints, after which the pen is finally ready to travel the world with its precious message: your image.

Produzione

Production

IT Le nostre linee di montaggio ad elevata automazione assicurano tempi di produzione rapidi e altamente competitivi: a seconda del modello, i macchinari possono montare da 2.000 a 6.000 pezzi l'ora. Automazione significa anche garanzia di funzionalità: rigorosi controlli qualitativi verificano ad ogni fase del montaggio il perfetto funzionamento di ogni penna.

EN Our highly automated assembly lines guarantee rapid, extremely competitive manufacturing times: depending on the model, our machinery can assemble from 2,000 to 6,000 pcs per hour. Automation also means guaranteeing functionality: strict quality checks make sure that all our pens operate perfectly at each stage of their assembly.

Responsabilità

Responsibility

IT La certificazione di provenienza esclusivamente italiana garantisce che i nostri articoli da scrittura non provengano da sfruttamento di manodopera minorile o da condizioni lavorative in contrasto con il rispetto dei diritti fondamentali dei lavoratori. Chiediamo la stessa garanzia anche ai nostri fornitori italiani e tedeschi di materie prime. Anche la scelta di una penna può contribuire a diffondere la cultura e il rispetto della dignità dei lavoratori.

EN The certificate of origin for our pens also guarantees that no child labour is involved in their manufacture, nor working conditions that do not respect workers' basic rights. We demand the same guarantee from our Italian and German raw materials suppliers. Even a pen can help to spread the culture and respect of the dignity of workers.

Flow Pure

pura ed essenziale
free from extra

NEW



**L'essenza
del design.**

The essence of design.

Flow Pure

informazioni tecniche

technical information

NEW

Tampografia e serigrafia disponibili anche su fusto gommato.

Pad and screen printing also available on rubberised barrel.

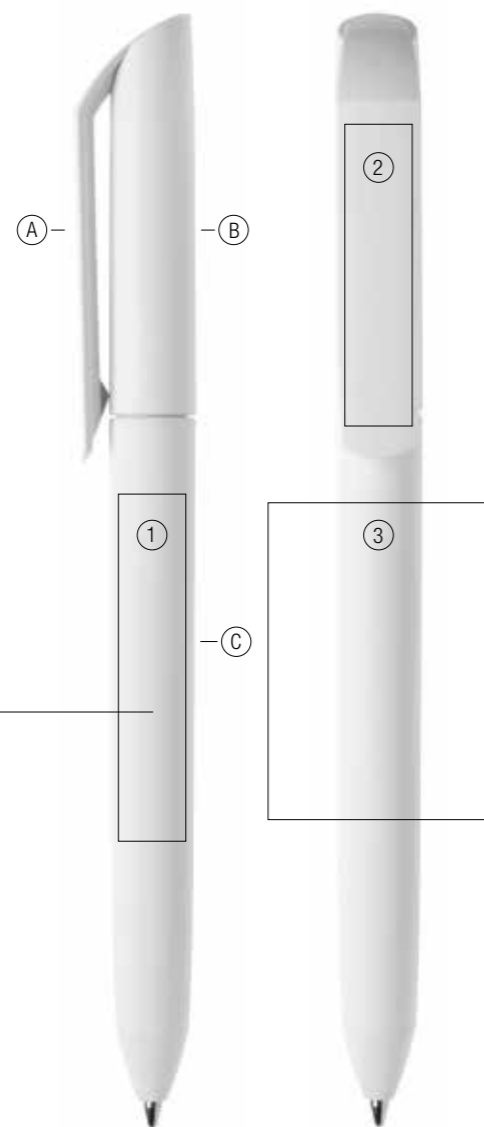

È possibile combinare particolari di colori diversi della stessa versione (o codice), oppure abbinare elementi di versioni differenti.

You can combine differently coloured parts from the same version (or code number), or elements from different versions.

- A** clip
- B** cappuccio
- C** fusto

- A** clip
- B** cap
- C** barrel

1/5

CARATTERISTICHE

- meccanismo a rotazione
- realizzata in plastica ABS, atossica e ad alta resistenza
- refill Jumbo, inchiostro blu e nero
- disponibile con fusto e cappuccio gommati

FEATURES

- twist-action
- made of non-toxic highly resistant ABS plastic
- Jumbo refill, blue and black ink
- available with rubberised barrel and cap

2/5

AREA STAMPABILE

- 1 tampografia 50 x 9 mm
- 2 tampografia 40 x 9 mm
- 3 serigrafia 45 x 30 mm

PRINT AREA

- 1 pad printing 50 x 9 mm
- 2 pad printing 40 x 9 mm
- 3 screen printing 45 x 30 mm

3/5

FUSTO E CAPPUCCIO

GOM



4/5

CLIP

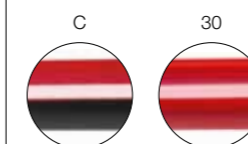

5/5

COLORAZIONI

- coprenti



- trasparenti



NEW

- fluo coprenti



NEW

- fluo trasparenti



COLOURS

- solid



- transparent



- solid fluo

- transparent fluo

Flow Pure F2 P – GOM K

fusto e cappuccio in colore nero gommato,
clip in colore coprente lucido
black barrel and cap with rubber finish,
solid colour clip with glossy finish

NEW



70 crema / tampografia 40 x 9 mm
70 cream / pad printing 40 x 9 mm



03



18 arancio / tampografia 40 x 9 mm
18 orange / pad printing 40 x 9 mm



15



60



61



71



72



79



09



26 acquamarina / tampografia 40 x 9 mm
26 aquamarine / pad printing 40 x 9 mm



27



64



77



12



05



04

**Il nero è il nuovo
protagonista, in abbinamento
con i colori coprenti.**

*Black in combination with solid
colours is the new highlight.*

Flow Pure F2 P – GOM CB

fusto e cappuccio in colore coprente gommato,
clip in colore bianco lucido
solid colour barrel and cap with rubber finish,
solid white colour clip with glossy finish

NEW

71 viola chiaro / tampografia 40 x 9 mm
71 light violet / pad printing 40 x 9 mm



60 rosa / tampografia 40 x 9 mm
60 pink / pad printing 40 x 9 mm



**Gommatura integrale:
fusto e cappuccio soft touch.**

*Rubberised all over:
soft touch barrel and cap.*

04 nero / tampografia 40 x 9 mm
04 black / pad printing 40 x 9 mm

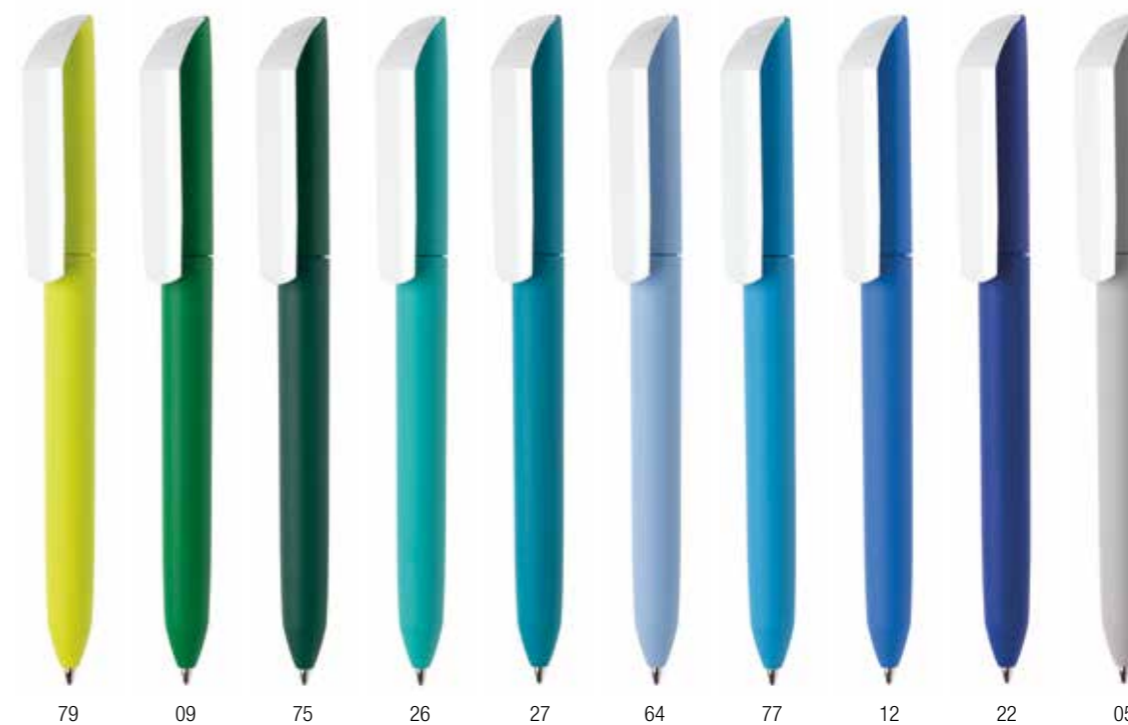

Flow Pure F2 P – GOM 30

fusto e cappuccio in colore coprente gommato,
clip in colore trasparente lucido
solid colour barrel and cap with rubber finish,
transparent colour clip with glossy finish

NEW

38 marrone / tampografia 40 x 9 mm
38 brown / pad printing 40 x 9 mm



Anche il fusto
è **stampabile**
con **tampografia**
o **serigrafia!**

*Even the rubberised barrel
can be pad or silk-screen printed!*

50 nero / tampografia 40 x 9 mm
50 black / pad printing 40 x 9 mm



49 verde / tampografia 50 x 9 mm
49 green / pad printing 50 x 9 mm



Flow Pure F2 P – GOM CF

fusto e cappuccio in colore fluo gommato,
clip in colore fluo coprente lucido
solid fluo colour barrel and cap with rubber finish,
solid fluo colour clip with glossy finish

NEW

**switch
on fluo**



56 fucsia / tampografia 40 x 9 mm
56 fuchsia / pad printing 40 x 9 mm



08



02



17



14

Flow Pure F2 P – GOM KF

fusto e cappuccio in colore nero gommato,
clip in colore fluo coprente lucido
black barrel and cap with rubber finish,
solid fluo colour clip with glossy finish

NEW

**switch
on fluo**



02 giallo / tampografia 40 x 9 mm
02 yellow / pad printing 40 x 9 mm



17



14 rosso corallo / tampografia 40 x 9 mm
14 coral red / pad printing 40 x 9 mm



56



08

Flow Pure

F2 P – GOM 30 F

fusto e cappuccio in colore fluo gommato,
clip in colore fluo trasparente lucido
solid fluo colour barrel and cap with rubber finish,
transparent fluo colour clip with glossy finish

NEW

**switch
on fluo**



20



33 arancio / tampografia 40 x 9 mm
33 orange / pad printing 40 x 9 mm



24



46



48 verde / tampografia 40 x 9 mm
48 green / pad printing 40 x 9 mm

Profilo minimal e volumi compatti.

*Minimal profile
and compact volumes.*

Questo è il risultato del nostro
percorso stilistico verso
l'essenzialità del design.

*This is the result of our styling
approach to the essentials of design.*

1/5

Flow

senti il cambiamento
feel the change



**L'evoluzione
della forma,
con e senza texture.**

*Evolution of shape,
with and without texturing.*

Flow
informazioni
tecniche
*technical
information*

**Tampografia
e serigrafia
disponibili
anche su fusto
gommato.**

*Pad and screen printing also
available on rubberised barrel.*



È possibile combinare particolari di colori diversi della stessa versione (o codice), oppure abbinare elementi di versioni differenti.

You can combine differently coloured parts from the same version (or code number), or elements from different versions.

- A** clip
- B** cappuccio
- C** fusto
- A** clip
- B** cap
- C** barrel

1/6

CARATTERISTICHE

- meccanismo a rotazione
- realizzata in plastica ABS, atossica e ad alta resistenza
- la cromatura della punta è ottenuta con trattamento galvanico
- refill Jumbo, inchiostro blu e nero
- il fusto è disponibile con superfici lucide o gommate
- nella versione Texture il cappuccio satinato è percorso interamente da una trama a nido d'ape

FEATURES

- twist-action
- made of non-toxic highly resistant ABS plastic
- galvanic process used to chrome tip
- Jumbo refill, blue and black ink
- the barrel is available in glossy or rubberised finish
- in the Texture version, the entire matt cap features a honeycomb design

2/6

AREA STAMPABILE

- 1** tampografia 46 x 9 mm
- 2** tampografia 40 x 9 mm
- 3** serigrafia 42 x 30 mm

PRINT AREA

- 1** pad printing 46 x 9 mm
- 2** pad printing 40 x 9 mm
- 3** screen printing 42 x 30 mm

3/6

FUSTO

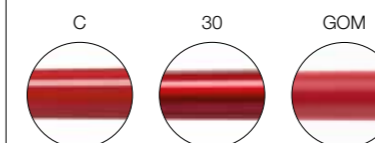

BARREL

4/6

CAPPUCCIO

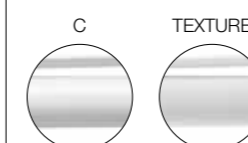

CAP

5/6

PUNTA

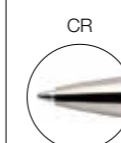

TIP

6/6

COLORAZIONI

- coprenti
 - 01 70 03 18 15 74 60 61 71
- trasparenti
 - 39 52 53 45 59 41 51 31 55
- trattamento galvanico

COLOURS

- solid
 - 25 73 79 09 75 26 27 64 77 12 22 05 04
- transparent
 - 37 38 78 49 47 34 67 44 30 50
- galvanic process

Flow

F1 – BC CR

fusto e clip in colore bianco coprente lucido,
cappuccio in colore coprente con finitura lucida, punta cromata
solid glossy white colour barrel and clip, solid colour cap
with glossy finish, chromed tip

**La clip dal profilo
affilato e aerodinamico
è indipendente dal
cappuccio che la ospita
per permettere nuovi
contrasti cromatici.**

*The slender, aerodynamic clip
is independent of the cap,
thus permitting new colour contrasts.*



03

15

74

60

61

71

25

73

79

18 arancio / tampografia 40 x 9 mm
18 orange / pad printing 40 x 9 mm



09

75

26

27

64

77 ciano / tampografia 46 x 9 mm
77 cyan / pad printing 46 x 9 mm



04 nero / tampografia 40 x 9 mm
04 black / pad printing 40 x 9 mm

77 ciano / tampografia 40 x 9 mm
77 cyan / pad printing 40 x 9 mm



12

22

05



Flow

F1 – B 30 CR

fusto bianco coprente lucido, clip in colore
trasparente con finitura lucida, punta cromata
solid white barrel with glossy finish, transparent
colour clip with glossy finish, chromed tip



39

52

53 arancio / tampografia 40 x 9 mm
53 orange / pad printing 40 x 9 mm



45

41

51

31 lilla / tampografia 40 x 9 mm
31 lilac / pad printing 40 x 9 mm



55

37



38

78

49

47

34

67

44

30

50 grigio scuro / tampografia 40 x 9 mm
50 dark grey / pad printing 40 x 9 mm



Flow

F1 – C CR

colori coprenti con finitura lucida, punta cromata
solid colours with glossy finish, chromed tip



01 bianco / tampografia 40 x 9 mm
01 white / pad printing 40 x 9 mm

77 ciano / tampografia 40 x 9 mm
77 cyan / pad printing 40 x 9 mm

77 ciano / tampografia 46 x 9 mm
77 cyan / pad printing 46 x 9 mm

Flow

F1 – 30 CR

colori trasparenti con finitura lucida, punta cromata
transparent colours with glossy finish, chromed tip



52



53



45



59



41



51



31



55



37



38



78



49



47



34



67



30



50

39 neutro / tampografia 40 x 9 mm
39 neutral / pad printing 40 x 9 mm

44 blu / tampografia 40 x 9 mm
44 blue / pad printing 40 x 9 mm

Flow TEXTURE

F1 T – GOM C CR

fusto in colore coprente gommato, clip in colore coprente lucido, cappuccio texturizzato in colore coprente con finitura satinata, punta cromata
solid colour barrel with rubber finish, solid colour clip with glossy finish, textured solid colour cap with matt finish, chromed tip

18 arancio / tampografia 40 x 9 mm
18 orange / pad printing 40 x 9 mm



01 70 03



15 74 60 61 71 25 73



79 09 75 26 27 64 77 12 22 05

04 nero / tampografia 40 x 9 mm
04 black / pad printing 40 x 9 mm

**Elemento distintivo:
cappuccio arricchito
da una texture.**

Distinctive feature: textured cap.



Flow TEXTURE

F1 T – GOM CB CR

fusto in colore coprente gommato, clip in colore bianco lucido, cappuccio
texturizzato in colore coprente con finitura satinata, punta cromata
solid colour barrel with rubber finish, solid glossy white colour clip,
textured solid colour cap with matt finish, chromed tip

73 marrone / tampografia 40 x 9 mm
73 brown / pad printing 40 x 9 mm

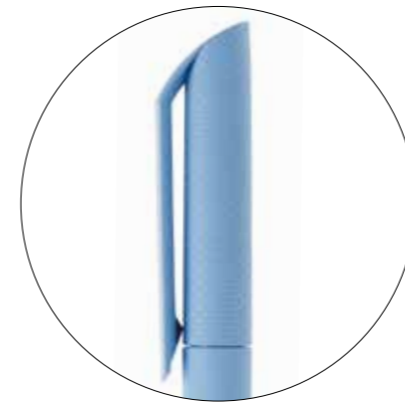

Texture costituita da piccole celle esagonali che ricordano un nido d'ape: un design dinamico che dona eleganza visiva e tattile.

Textured with small hexagonal cells that recall a honeycomb: a dynamic design of visual and tactile elegance.

05 grigio / tampografia 40 x 9 mm
05 grey / pad printing 40 x 9 mm



26 acquamarina / tampografia 40 x 9 mm
26 aquamarine / pad printing 40 x 9 mm

Flow TEXTURE

F1 T – GOM 30 CR

fusto in colore coprente gommato, clip in colore trasparente lucido,
cappuccio texturizzato in colore coprente con finitura satinata, punta cromata
solid colour barrel with rubber finish, transparent glossy colour clip,
textured solid colour cap with matt finish, chromed tip



39 52 53 45



59 rosa / tampografia 40 x 9 mm
59 pink / pad printing 40 x 9 mm



41 31 55 37



38 78 49 47



30 grigio chiaro / tampografia 40 x 9 mm
30 light grey / pad printing 40 x 9 mm



67 44



50

Dot

diversa da tutte, punto
different from the rest, full stop

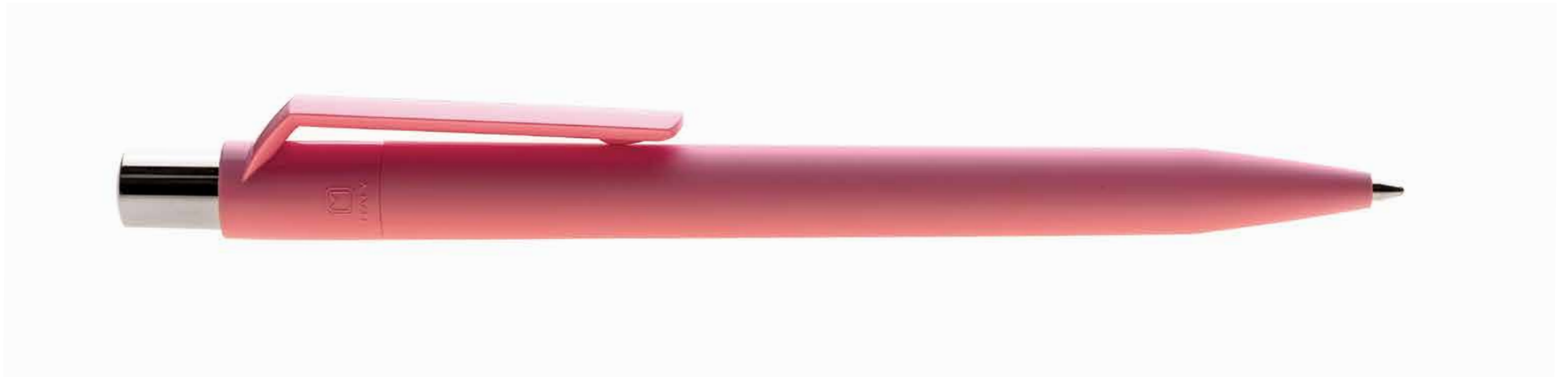

**È nei dettagli
che rivela
la sua originalità.**

*A pen that reveals
its originality in its details.*

Dot
informazioni
tecniche
*technical
information*

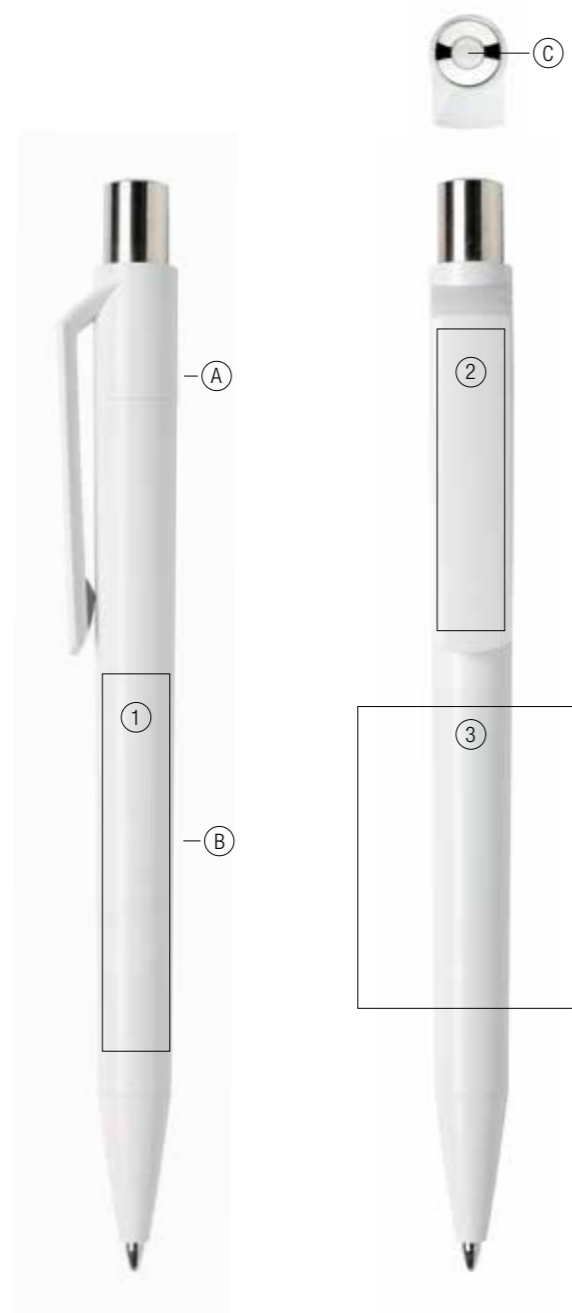

È possibile combinare particolari di colori diversi della stessa versione (o codice), oppure abbinare elementi di versioni differenti.

You can combine differently coloured parts from the same version (or code number), or elements from different versions.

- A clip
- B fusto
- C piccola sfera
- A clip
- B barrel
- C little sphere

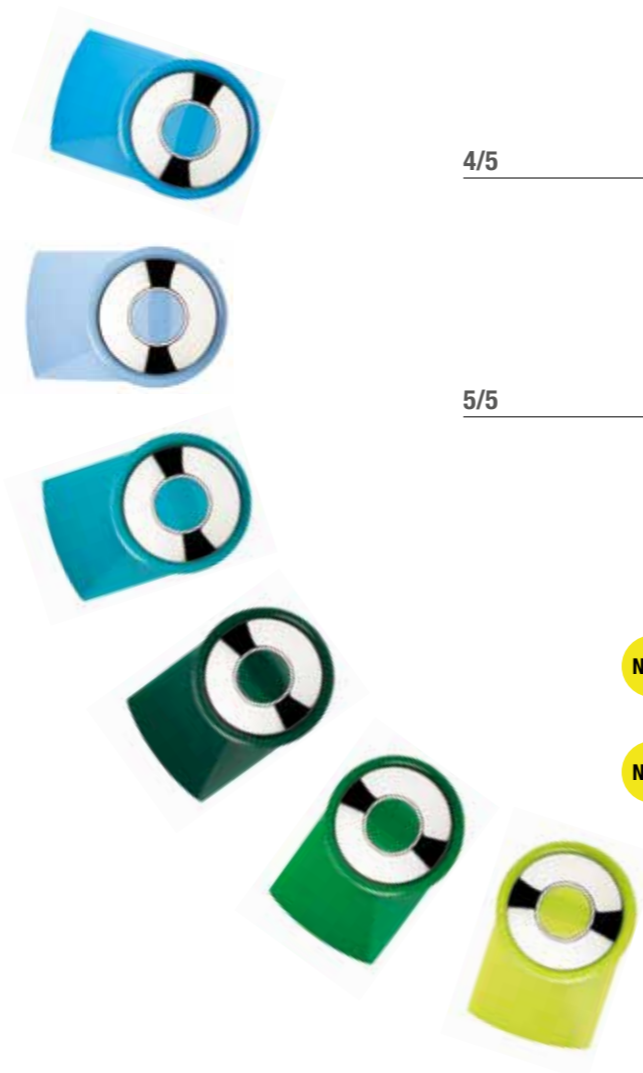

1/5

CARATTERISTICHE

- meccanismo a scatto, con molla di ritorno
- realizzata in plastica ABS atossica e ad alta resistenza
- la cromatura e la doratura del tappino sono ottenute con trattamento galvanico
- refill Jumbo, inchiostro blu e nero
- il fusto è disponibile con superfici lucide o gommate
- le versioni con fusto gommato sono stampabili solo su clip

FEATURES

- retractable with return spring
- made of non-toxic, highly resistant ABS plastic
- galvanic process used to chrome and gold ABS push-button
- Jumbo refill, blue and black ink
- the barrel is available in glossy or rubberised finish
- rubberised barrel versions are only printable on the clip

2/5

AREA STAMPABILE

- 1 tampografia 50 x 9 mm
- 2 tampografia 40 x 9 mm
- 3 serigrafia 40 x 30 mm

PRINT AREA

- 1 pad printing 50 x 9 mm
- 2 pad printing 40 x 9 mm
- 3 screen printing 40 x 30 mm

3/5

FUSTO

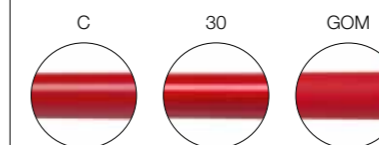

BARREL

4/5

TAPPINO

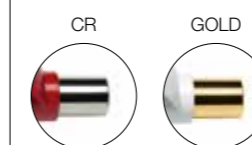

PUSH-BUTTON

5/5

COLORAZIONI

- coprenti



- trasparenti



NEW

- fluo coprenti



NEW

- fluo trasparenti



- trattamento galvanico



COLOURS

- solid



- transparent



- solid fluo

- transparent fluo

- galvanic process

Dot

D1 – B CR

fusto e clip in colore bianco coprente con finitura lucida,
piccola sfera in colore coprente lucido, tappino cromato
solid white colour barrel and clip with glossy finish,
solid glossy colour little sphere, chromed push-button



18

15

60

61

71

25

73



03 giallo / tampografia 40 x 9 mm
03 yellow / pad printing 40 x 9 mm

74 bordeaux / tampografia 40 x 9 mm
74 burgundy / pad printing 40 x 9 mm



09

75

27

64

77

12 azzurro / tampografia 40 x 9 mm
12 light blue / pad printing 40 x 9 mm

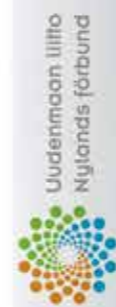

79 lime / tampografia 40 x 9 mm
79 lime / pad printing 40 x 9 mm



22

05

04

Dot

D1 – BC CR

fusto bianco coprente lucido, clip e piccola sfera
in colore coprente con finitura lucida, tappino cromato
solid glossy white colour barrel, solid colour clip
and little sphere with glossy finish, chromed push-button



61 magenta / tampografia 40 x 9 mm
61 magenta / pad printing 40 x 9 mm



71 25 72 73



75 verde scuro / tampografia 40 x 9 mm
75 dark green / pad printing 40 x 9 mm



79 09



27 64 77 12 22



05 grigio / tampografia 40 x 9 mm
05 grey / pad printing 40 x 9 mm



04

**Estetica della clip
molto ricercata,
per far risaltare
la forza e il carattere
di ogni brand.**

The clip is of highly refined appearance to highlight the strength and personality of each brand.

Dot

D1 – B 30 CR

fusto bianco coprente lucido, clip in colore
trasparente con finitura lucida, piccola sfera
in colore coprente lucido, tappino cromato
solid glossy white colour barrel, transparent colour
clip with glossy finish, solid glossy colour little
sphere, chromed push-button

**Il meccanismo è a scatto
con molla di ritorno
in tutte le combinazioni.**

Retractable with return spring in all versions.



55 viola scuro / tampografia 40 x 9 mm
55 dark violet / pad printing 40 x 9 mm



49 verde / tampografia 40 x 9 mm
49 green / pad printing 40 x 9 mm



Dot D1 – CB CR

fusto e piccola sfera in colore coprente lucido,
clip in colore bianco lucido, tappino cromato
solid colour barrel and little sphere with glossy finish,
solid glossy white colour clip, chromed push-button

NEW



15 rosso / tampografia 40 x 9 mm
15 red / pad printing 40 x 9 mm



04 nero / tampografia 40 x 9 mm
04 black / pad printing 40 x 9 mm



Dot

D1 – C CR

colori coprenti con finitura lucida, tappino cromato
solid colours with glossy finish, chromed push-button



18 arancio / tampografia 40 x 9 mm
18 orange / pad printing 40 x 9 mm



74 bordeaux / tampografia 40 x 9 mm
74 burgundy / pad printing 40 x 9 mm



64 azzurro pastello / tampografia 40 x 9 mm
64 pastel blue / pad printing 40 x 9 mm



04 nero / tampografia 40 x 9 mm
04 black / pad printing 40 x 9 mm



Dot

D1 – 30 CR

colori trasparenti con finitura lucida, piccola sfera
in colore coprente lucido, tappino cromato
transparent colours with glossy finish, solid glossy
colour little sphere, chromed push-button

**Le componenti di Dot
si prestano ad originali
accostamenti cromatici per
soddisfare ogni esigenza
di personalizzazione.**

*Dot components permit original colour combinations
to cater to all personalisation requirements.*



39



53

45

41

55

37

38

52 giallo / tampografia 40 x 9 mm
52 yellow / pad printing 40 x 9 mm



78 lime / tampografia 40 x 9 mm
78 lime / pad printing 40 x 9 mm



49

47

67

44

50

Dot D1 – GOM CB CR

fusto in colore coprente gommato, clip in colore bianco lucido,
piccola sfera in colore coprente lucido, tappino cromato
solid colour barrel with rubber finish, solid glossy white colour clip,
solid glossy colour little sphere, chromed push-button

NEW



25 viola scuro / tampografia 40 x 9 mm
25 dark violet / pad printing 40 x 9 mm

64 azzurro pastello / tampografia 40 x 9 mm
64 pastel blue / pad printing 40 x 9 mm

18 arancio / tampografia 40 x 9 mm
18 orange / pad printing 40 x 9 mm

05 grigio / tampografia 40 x 9 mm
05 grey / pad printing 40 x 9 mm

Dot D1 – GOM C CR

fusto in colore coprente gommato, clip e piccola sfera
in colore coprente con finitura lucida, tappino cromato
solid colour barrel with rubber finish, solid colour clip
and little sphere with glossy finish, chromed push-button



71 viola chiaro / tampografia 40 x 9 mm
71 light violet / pad printing 40 x 9 mm

03 giallo / tampografia 40 x 9 mm
03 yellow / pad printing 40 x 9 mm



22 blu / tampografia 40 x 9 mm
22 blue / pad printing 40 x 9 mm



Dot

D1 – GOM 30 CR

fusto in colore coprente gommato, clip in colore trasparente con finitura lucida, piccola sfera in colore coprente lucido, tappino cromato
solid colour barrel with rubber finish, transparent colour clip with glossy finish, solid glossy colour little sphere, chromed push-button



38 marrone / tampografia 40 x 9 mm
38 brown / pad printing 40 x 9 mm



50 grigio scuro / tampografia 40 x 9 mm
50 dark grey / pad printing 40 x 9 mm

Dot D1 – C GOLD

colori coprenti con finitura
lucida, tappino dorato
solid colours with glossy finish,
gilded push-button

NEW



04

01 bianco / tampografia 40 x 9 mm
01 white / pad printing 40 x 9 mm

Dot D1 – GOM CB F CR

fusto in colore fluo coprente gommato, clip in colore bianco coprente lucido,
piccola sfera in colore fluo coprente lucido, tappino cromato
solid fluo colour barrel with rubber finish, solid glossy white colour clip,
solid glossy fluo colour little sphere, chromed push-button

NEW



17

14

56

08

02 giallo / tampografia 40 x 9 mm
02 yellow / pad printing 40 x 9 mm

**switch
on fluo**

Dot D1 – GOM KF CR

fusto in colore nero coprente gommato, clip e piccola sfera in colore fluo coprente lucido, tappino cromato
solid black colour barrel with rubber finish, solid fluo colour clip and little sphere with glossy finish, chromed tip

**switch
on fluo**

NEW



17 arancio / tampografia 40 x 9 mm
17 orange / pad printing 40 x 9 mm



02



14 rosso corallo / tampografia 40 x 9 mm
14 coral red / pad printing 40 x 9 mm



56



08



Dot D1 – GOM 30 F CR

fusto in colore fluo coprente gommato, clip in colore fluo trasparente lucido, piccola sfera in colore fluo coprente lucido, tappino cromato
solid fluo colour barrel with rubber finish, transparent glossy fluo colour clip, solid glossy fluo colour little sphere, chromed push-button

**switch
on fluo**

NEW



20



33



24



46

48 verde / tampografia 40 x 9 mm
48 green / pad printing 40 x 9 mm



Zink

solide geometrie
solid geometries

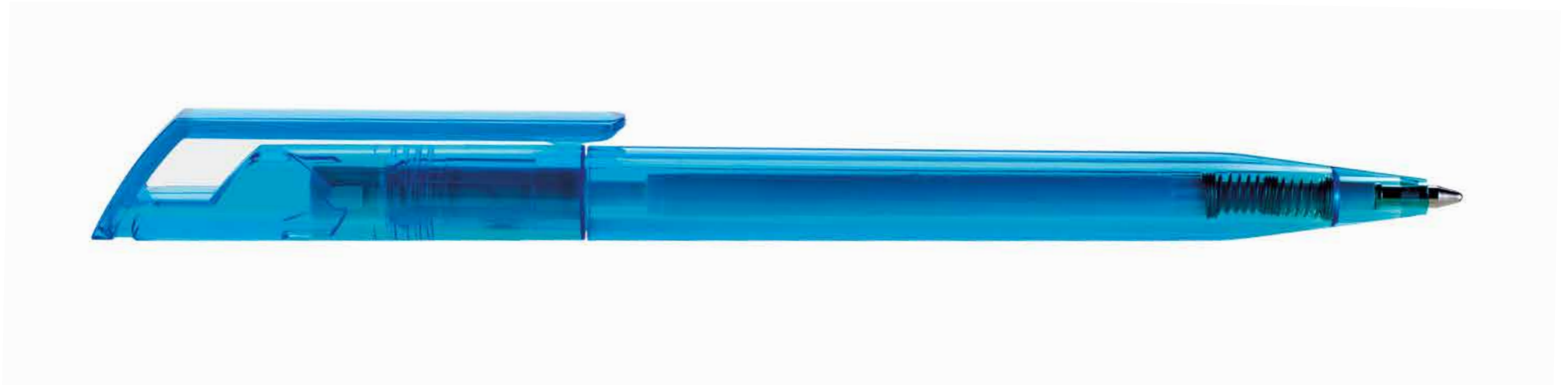

**Una penna
dal profilo tagliente
e dal carattere deciso.**

*A pen with a clean-cut profile
and strong personality.*

Zink
 informazioni
 tecniche
*technical
 information*

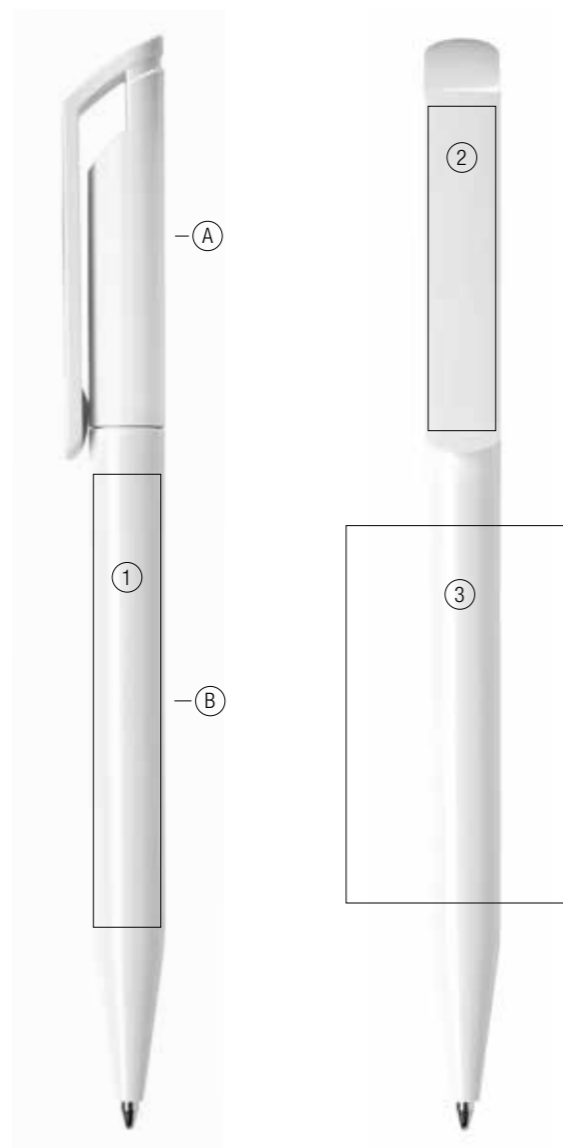

È possibile combinare particolari di colori diversi della stessa versione (o codice), oppure abbinare elementi di versioni differenti.

You can combine differently coloured parts from the same version (or code number), or elements from different versions.

- A cappuccio
- A cap
- B fusto
- B barrel

1/5

CARATTERISTICHE

- meccanismo a rotazione
- realizzata in plastica ABS atossica e ad alta resistenza
- refill Jumbo, inchiostro blu e nero
- disponibile con superfici lucide

FEATURES

- twist-action
- made of non-toxic, highly resistant ABS plastic
- Jumbo refill, blue and black ink
- available in glossy finish

2/5

AREA STAMPABILE

- 1 tampografia 60 x 9 mm
- 2 tampografia 43 x 9 mm
- 3 serigrafia 50 x 30 mm

PRINT AREA

- 1 pad printing 60 x 9 mm
- 2 pad printing 43 x 9 mm
- 3 screen printing 50 x 30 mm

3/5

FUSTO

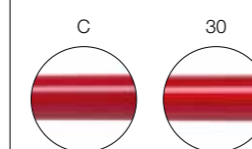

BARREL

4/5

CAPPUCCIO

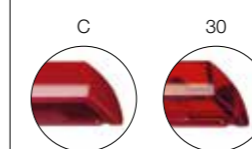

CAP

5/5

COLORAZIONI

- coprenti



- trasparenti



NEW

- fluo coprenti



NEW

- fluo trasparenti



COLOURS

- solid

- transparent

- solid fluo

- transparent fluo

Zink Z1 - C

colori coprenti con finitura lucida
solid colours with glossy finish

**Architettura corposa
e robusta per un profilo
dal rigore geometrico.**

*Solid, sturdy architecture
for a profile of geometric precision.*



Zink

Z1 – B 30

fusto bianco coprente lucido, cappuccio
in colore trasparente con finitura lucida
solid glossy white barrel, transparent
colour cap with glossy finish

41 magenta / tampografia 43 x 9 mm
41 magenta / pad printing 43 x 9 mm



39 52 53 45



51 55 37 38

**La clip colpisce per la sua
lunghezza, una garanzia
di forte impatto visivo.**

*The clip's striking length guarantees
a strong visual impact.*



49 47 67 44 50

78 lime / tampografia 43 x 9 mm
78 lime / pad printing 43 x 9 mm

Zink Z1 – 30

colori trasparenti con finitura lucida
transparent colours with glossy finish

37 ambra / tampografia 43 x 9 mm
37 amber / pad printing 43 x 9 mm



67 ciano / tampografia 43 x 9 mm
67 cyan / pad printing 43 x 9 mm

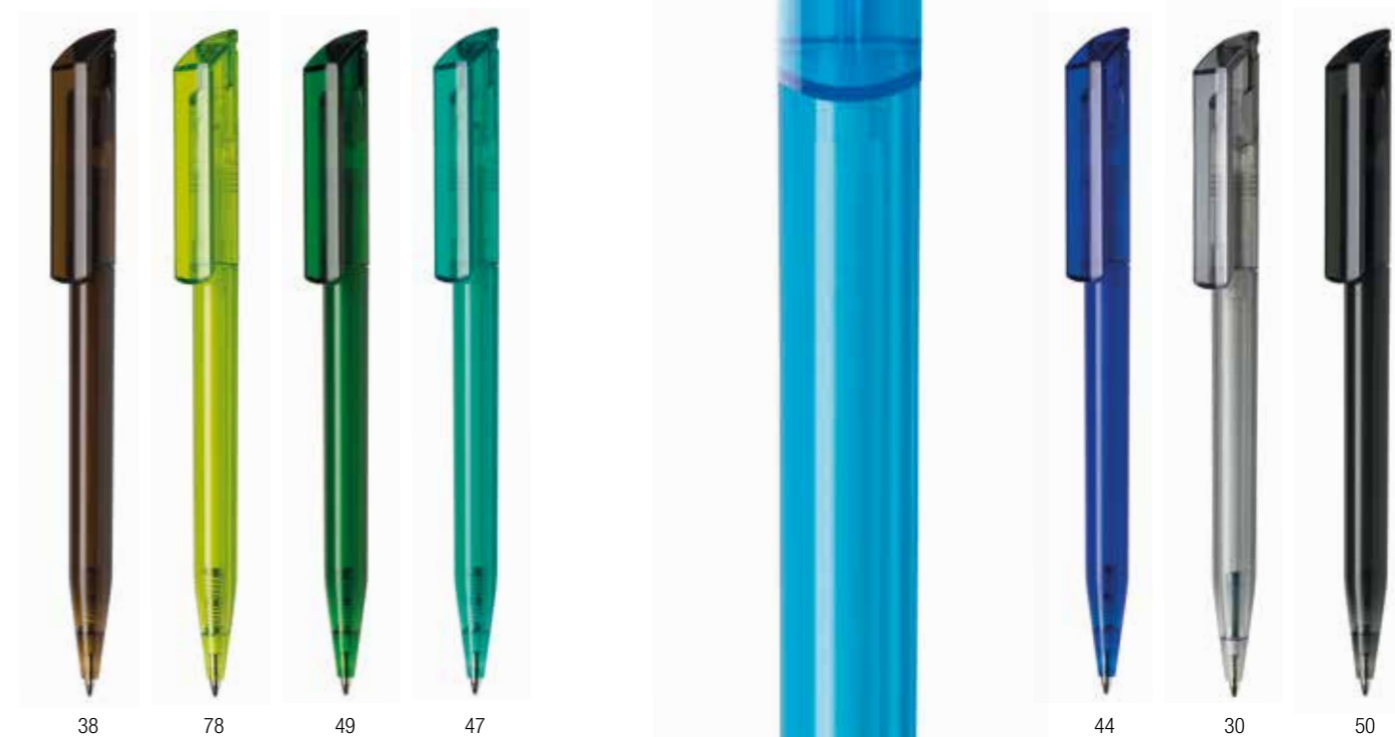

**Il fusto slanciato bilancia
la solida struttura.**

*Its sturdy structure is offset by
the slim, streamlined barrel.*



2/5

Zink Z1 – CF

colori fluo coprenti con finitura lucida
solid fluo colours with glossy finish

NEW

**switch
on fluo**



02



17 arancio / tampografia 43 x 9 mm
17 orange / pad printing 43 x 9 mm



14



56

**Nuovi colori fluo,
tonalità intense
e vibranti.**

*New fluo colours,
intense and vibrant shades.*



08 verde / tampografia 43 x 9 mm
08 green / pad printing 43 x 9 mm

View

carattere incisivo
decisive personality



**Sprigiona grinta
da ogni punto
di vista e affascina
per l'eleganza.**

*Exudes boldness from every angle
and captivates with its elegance.*

View
informazioni
tecniche
*technical
information*

**Soluzioni
di stampa
sulla clip.**

*Print solutions
for the clip.*

- ① tampografia 40 x 6 mm
pad printing 40 x 6 mm
- ② incisione laser 30 x 7 mm
laser engraving 30 x 7 mm

Esempi di realizzazioni alle pp. 92-95
Product examples at pp. 92-95

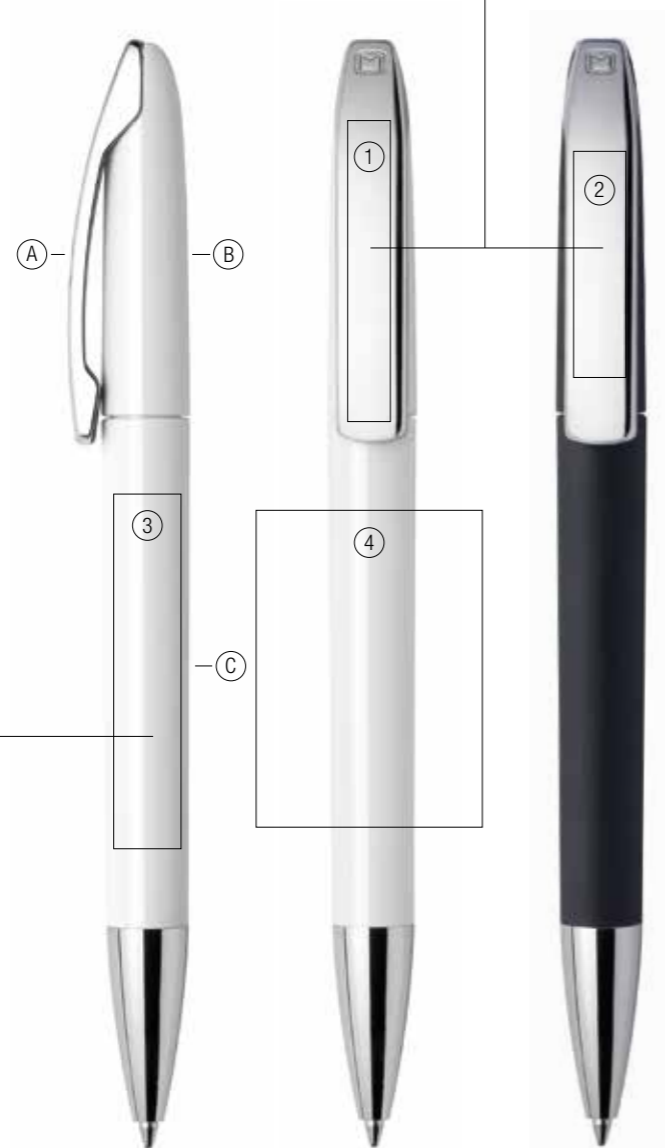

**Tampografia
e serigrafia
disponibili
anche su fusto
gommato.**

*Pad and screen printing also
available on rubberised barrel.*

È possibile combinare particolari di colori diversi della stessa versione (o codice), oppure abbinare elementi di versioni differenti.

You can combine differently coloured parts from the same version (or code number), or elements from different versions.

- Ⓐ clip
- Ⓑ cappuccio
- Ⓒ fusto
- Ⓐ clip
- Ⓑ cap
- Ⓒ barrel

1/5

CARATTERISTICHE

- meccanismo a rotazione
- realizzata in plastica ABS atossica e ad alta resistenza
- clip in metallo cromato
- la cromatura della punta è ottenuta con trattamento galvanico
- refill Jumbo, inchiostro blu e nero
- disponibile con superfici lucide, gommate o verniciate in colore alluminio

FEATURES

- twist-action
- made of non-toxic, highly resistant ABS plastic
- metal chrome finish clip
- galvanic process used to chrome tip
- Jumbo refill, blue and black ink
- available in glossy, matt, rubberised or aluminium painted finish

2/5

AREA STAMPABILE

- ③ tampografia 47 x 9 mm
- ④ serigrafia 42 x 30 mm

PRINT AREA

- ③ pad printing 47 x 9 mm
- ④ screen printing 42 x 30 mm

3/5

FUSTO

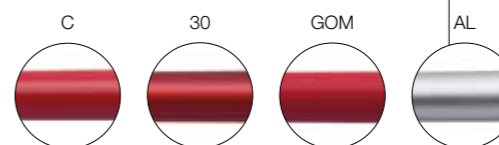

BARREL

4/5

PUNTA

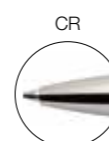

TIP

5/5

COLORAZIONI

- coprenti
- ① 70 03 18 15 74 60 61 71
- trasparenti
- ③ 9 52 53 45 51 55 49 47 44
- vernici metallizzate
- trattamento galvanico

COLOURS

- solid
- 25 72 73 79 09 75 27 64 12 22 04
- transparent
- 40
- metallic paintings
- galvanic process

View

V1 – C CR

colori coprenti con finitura lucida, clip in metallo cromato, punta cromata
solid colours with glossy finish, metal chrome finish clip, chromed tip

La linea affilata del cappuccio dà armonia e bilancia l'imponenza della clip.

The sleek design of the cap adds elegance and balances the large clip.



01

70

03

18

15

74

60 rosa / serigrafia 42 x 30 mm
60 pink / screen printing 42 x 30 mm



61

71



25

73



79 lime / serigrafia 42 x 30 mm
79 lime / screen printing 42 x 30 mm



09

75

27

64

12

22 blu / serigrafia 42 x 30 mm
22 blue / screen printing 42 x 30 mm



04

View

V1 – 30 CR

colori trasparenti con finitura lucida,
clip in metallo cromato, punta cromata
transparent colours with glossy finish,
metal chrome finish clip, chromed tip



39 neutro / serigrafia 42 x 30 mm
39 neutral / screen printing 42 x 30 mm

View

V1 – AL CR

fusto e cappuccio verniciati in colore alluminio,
clip in metallo cromato, punta cromata
aluminium painted finish barrel and cap,
metal chromed clip, chromed tip



**Concepita per
valorizzare l'unicità
di ogni brand.**

*Designed to highlight the unique
character of each brand.*

alluminio / tampografia 47 x 9 mm
aluminium / pad printing 47 x 9 mm

View

V1 – GOM C CR T

fusto in colore coprente gommato, cappuccio colore coprente con finitura lucida, clip in metallo cromato con speciale verniciatura trasparente idonea a stampa tampografica, punta cromata
solid colour barrel with rubber finish, solid colour cap with glossy finish, metal chrome finish clip with special transparent painting suitable for pad printing, chromed tip

61 magenta / tampografia su clip 40 x 6 mm
61 magenta / pad printing on the clip 40 x 6 mm



03



15

74

60

18 arancio / tampografia su clip 40 x 6 mm
18 orange / pad printing on the clip 40 x 6 mm



71

25

72



73

79

09

75

27

64 azzurro pastello / tampografia su clip 40 x 6 mm
64 pastel blue / pad printing on the clip 40 x 6 mm



12

22

04 nero / tampografia su clip 40 x 6 mm
04 black / pad printing on the clip 40 x 6 mm



tampografia pad printing

Via libera ai colori, anche su metallo!

Free rein to **colours**
on metals too!

Tutta la bellezza dei colori è ora realizzabile anche sulla **clip in metallo**, grazie ad una speciale verniciatura trasparente preliminare. La stampa tampografica su metallo viene eseguita con inchiostri bicomponenti.

All the beauty that colours bring can now be applied to the **metal clip** using a special preliminary transparent paint. Pad printing on metal is done with bi-component paints.

View

V1 – GOM C CR

fusto in colore coprente gommato, cappuccio in colore coprente
con finitura lucida, clip in metallo cromato, punta cromata
solid colour barrel with rubber finish, solid colour cap
with glossy finish, metal chrome finish clip, chromed tip



03 giallo / incisione laser 30 x 7 mm
03 yellow / laser engraving 30 x 7 mm



15 rosso / incisione laser 30 x 7 mm
15 red / laser engraving 30 x 7 mm

74 bordeaux / incisione laser 30 x 7 mm
74 burgundy / laser engraving 30 x 7 mm



22 blu / incisione laser 30 x 7 mm
22 blue / laser engraving 30 x 7 mm

09 verde / incisione laser 30 x 7 mm
09 green / laser engraving 30 x 7 mm

laser
laser

**Valorizza il prestigio
di un marchio con
raffinata eleganza.**

*Refined elegance to enhance
the prestige of a brand.*

Per una personalizzazione più raffinata si può
scegliere l'**elegante precisione** della stampa laser.

For more refined personalisation choose
the **elegant precision** of laser printing.



04 nero / incisione laser 30 x 7 mm
04 black / laser engraving 30 x 7 mm



Tag

eleganza imponente
imposing elegance



**Design semplice
e raffinato, omaggio
all'eleganza perfetta.**

*Clean-cut, refined design,
a tribute to perfect elegance.*

Tag
informazioni
tecniche
*technical
information*

**Tampografia
e serigrafia
disponibili
anche su fusto
gommato.**

*Pad and screen printing also
available on rubberised barrel.*

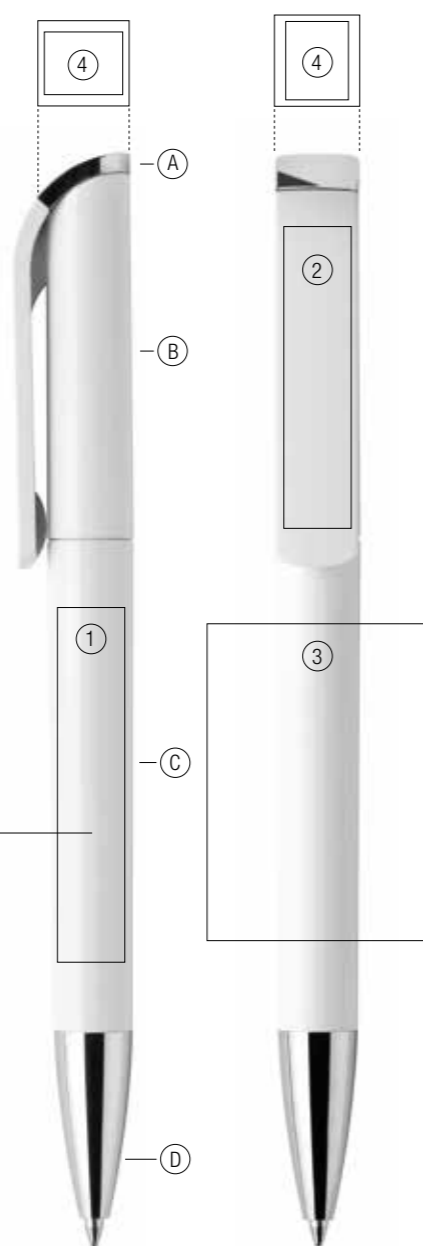

- | | |
|------------|----------|
| Ⓐ tassello | Ⓐ plug |
| Ⓑ clip | Ⓑ clip |
| Ⓒ fusto | Ⓒ barrel |
| Ⓓ punta | Ⓓ tip |

È possibile combinare particolari di colori diversi della stessa versione (o codice), oppure abbinare elementi di versioni differenti.

You can combine differently coloured parts from the same version (or code number), or elements from different versions.

1/5

CARATTERISTICHE

- meccanismo a rotazione
- realizzata in plastica ABS atossica e ad alta resistenza
- la cromatura della punta e del tassello superiore è ottenuta con trattamento galvanico
- refill Jumbo, inchiostro blu e nero
- disponibile con superfici lucide, satinare, gommate o verniciate con colori metallizzati o alluminio

FEATURES

- twist-action
- made of non-toxic, highly resistant ABS plastic
- galvanic process used to chrome tip and upper plug
- Jumbo refill, blue and black ink
- available in glossy, matt, rubberised and metallic or aluminium painted finish

2/5

AREA STAMPABILE

- ① tampografia 47 x 9 mm
- ② tampografia 40 x 9 mm
- ③ serigrafia 42 x 30 mm
- ④ tampografia 8 x 10 mm

PRINT AREA

- ① pad printing 47 x 9 mm
- ② pad printing 40 x 9 mm
- ③ screen printing 42 x 30 mm
- ④ pad printing 8 x 10 mm

3/5

FUSTO

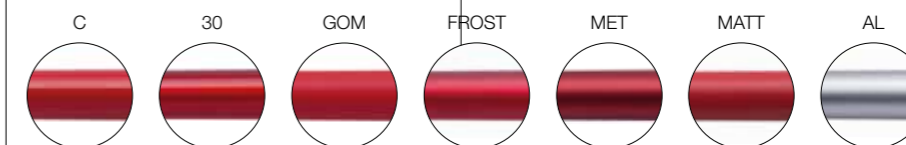

BARREL

4/5

PUNTA E TASSELLO

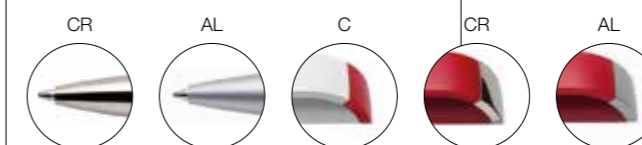

TIP AND PLUG

5/5

COLORAZIONI

- coprenti
 - 01 70 03 18 15 74 60 61 71 25 72 73 79 09 75 27 64 12 22 04
- trasparenti
 - 39 52 53 45 51 55 49 47 44 40
- vernici metallizzate
 - 92 83 85 94 95 96
- trattamento galvanico

COLOURS

- solid
- transparent
- metallic paintings
- galvanic process

Tag

TA1 – MATT AL B

colori coprenti con finitura satinata, tassello superiore in colore
coprente con finitura lucida, punta verniciata in colore alluminio
solid colours with matt finish, solid colour upper plug
with glossy finish, aluminium painted finish tip



01 bianco / tampografia 40 x 9 mm
01 white / pad printing 40 x 9 mm

serigrafia 42 x 30 mm
screen printing 42 x 30 mm



03

18

15

74



61 magenta / tampografia 40 x 9 mm
61 magenta / pad printing 40 x 9 mm



71

25



72

73

79

09

27

64 azzurro pastello / tampografia 40 x 9 mm
64 pastel blue / pad printing 40 x 9 mm



12

22

04

Tag TA1 – B CR

colori coprenti con finitura lucida, punta cromata
solid colours with glossy finish, chromed tip



15 rosso / tampografia 40 x 9 mm
15 red / pad printing 40 x 9 mm

04 nero / tampografia 40 x 9 mm
04 black / pad printing 40 x 9 mm

Tag TA1 – CB CR

colori coprenti con finitura lucida, punta cromata
solid colours with glossy finish, chromed tip



18 arancio / tampografia 40 x 9 mm
18 orange / pad printing 40 x 9 mm

61 magenta / tampografia 40 x 9 mm
61 magenta / pad printing 40 x 9 mm

Tag

TA1 – MATT AL

colori coprenti con finitura satinata, tassello superiore e punta verniciati in colore alluminio
solid colours with matt finish, aluminium painted finish upper plug and tip



01 bianco / tampografia 40 x 9 mm
01 white / pad printing 40 x 9 mm



03



18 arancio / tampografia 40 x 9 mm
18 orange / pad printing 40 x 9 mm

Tag

TA1 – FROST AL

colori trasparenti con finitura satinata, tassello superiore e punta verniciati in colore alluminio
transparent colours with matt finish, aluminium painted finish upper plug and tip



52 giallo / tampografia 40 x 9 mm
52 yellow / pad printing 40 x 9 mm



39



53



45 rosso / tampografia 40 x 9 mm
45 red / pad printing 40 x 9 mm



51

55

47

49

44

40

Lo stile rigoroso è ingentilito dalla dolce curvatura della clip e del suo tassello di chiusura.

Its rigorous styling is softened by the smooth curve of the clip and closing plug.

Tag

TA1 – C CR

colori coprenti con finitura lucida,
tassello superiore e punta cromati
solid colours with glossy finish,
chromed upper plug and tip

**Eleganza e linearità
per esprimere tutta
la forza di un brand.**

*Elegance and linearity to express
all the strength of a brand.*

01 bianco / tampografia 40 x 9 mm
01 white / pad printing 40 x 9 mm



70 03 18 15 74 60 61 71 25 72

64 azzurro pastello / tampografia 40 x 9 mm
64 pastel light blue / pad printing 40 x 9 mm



79 09 75 27

73 marrone / tampografia 40 x 9 mm
73 brown / pad printing 40 x 9 mm



12 22 04

Tag

TA1 – 30 CR

colori trasparenti con finitura lucida,
tassello superiore e punta cromati
transparent colours with glossy finish,
chromed upper plug and tip

44 blu / tampografia 40 x 9 mm
44 blue / pad printing 40 x 9 mm

tampografia 47 x 9 mm
pad printing 47 x 9 mm



39 52 53 45 51 55 49 47



40

Tag

TA1 – GOM C CR

fusto in colore coprente gommato, clip in colore coprente
con finitura lucida, tassello superiore e punta cromati
solid colour barrel with rubber finish, solid colour clip
with glossy finish, chromed upper plug and tip

Fusto gommato: piace perché è bello da vedere e da toccare.

Rubber finish barrel: popular because it is good to look at and pleasant to touch.

04 nero / tampografia 40 x 9 mm
04 black / pad printing 40 x 9 mm



03 18 15 74 25 73 09 22

72 cuoio / tampografia 40 x 9 mm
72 leather / pad printing 40 x 9 mm



Tag

TA1 – MET AL

fusto e clip verniciati in colori metallizzati, tassello superiore e punta verniciati in colore alluminio
metallic colours painted finish barrel and clip, aluminium painted finish upper plug and tip



92

83



85 rosso / tampografia 40 x 9 mm
85 red / pad printing 40 x 9 mm



94

95

96

Tag

TA1 – AL CR

fusto e clip verniciati in colore alluminio, tassello superiore e punta cromati
aluminium painted finish barrel and clip, chromed upper plug and tip

alluminio / tampografia 40 x 9 mm
aluminum / pad printing 40 x 9 mm



Icon

design senza tempo
timeless design



**L'incontro tra passato,
presente e futuro.**

*A perfect synthesis of past,
present and future.*

Icon
informazioni
tecniche
*technical
information*

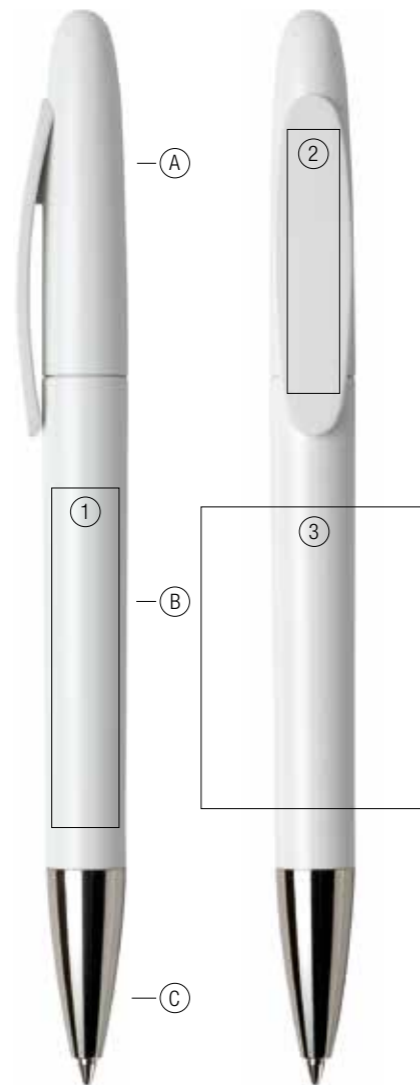

È possibile combinare particolari di colori diversi della stessa versione (o codice), oppure abbinare elementi di versioni differenti.

You can combine differently coloured parts from the same version (or code number), or elements from different versions.

- | | |
|-------------|----------|
| Ⓐ cappuccio | Ⓐ cap |
| Ⓑ fusto | Ⓑ barrel |
| Ⓒ punta | Ⓒ tip |

1/4

CARATTERISTICHE

- meccanismo a rotazione
- realizzata in plastica ABS, atossica e ad alta resistenza
- la cromatura e la doratura della punta in ABS sono ottenute con trattamento galvanico
- refill Jumbo, inchiostro blu e nero
- disponibile con superfici lucide, satinare o verniciate in colori metallizzati o alluminio

FEATURES

- twist-action
- made of non-toxic, highly resistant ABS plastic
- galvanic process used to chrome and gild ABS tip
- Jumbo refill, blue and black ink
- available in glossy, matt and metallic or aluminium painted finish

2/4

AREA STAMPABILE

- ① tampografia 45 x 9 mm
- ② tampografia 35 x 7 mm
- ③ serigrafia 40 x 30 mm

PRINT AREA

- ① pad printing 45 x 9 mm
- ② pad printing 35 x 7 mm
- ③ screen printing 40 x 30 mm

3/5

FUSTO

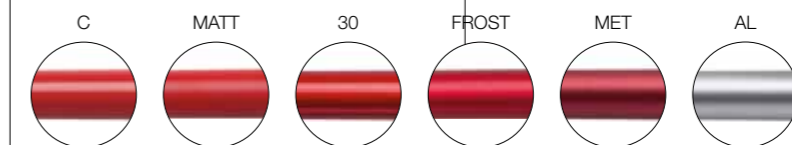

BARREL

4/5

PUNTA



TIP

5/5

COLORAZIONI

- coprenti
- 01 70 03 18 15 74 60 61 71
- trasparenti
- 39 52 53 45 51 55 49 47 44 40
- vernici metallizzate
- 92 83 85 94 95 96
- trattamento galvanico

COLOURS

- solid
- 25 72 73 79 09 75 27 64 12 22 04
- transparent
- 40
- metallic paintings
- galvanic process

Icon

IC400 – C

colori coprenti con finitura lucida
solid colours with glossy finish

**Design dal profilo
essenziale e armonico per
uno stile mai scontato
e sempre attuale.**

*Essential, harmonious design for a style that
is never banal and always up-to-date.*

18 arancio / tampografia 35 x 7 mm
18 orange / pad printing 35 x 7 mm



25 viola scuro / tampografia 35 x 7 mm
25 dark violet / pad printing 35 x 7 mm

Icon

IC400 – MATT

colori coprenti con finitura satinata
solid colours with matt finish

79 lime / tampografia 35 x 7 mm
79 lime / pad printing 35 x 7 mm



Icon

IC400 – 30

colori trasparenti con finitura lucida
transparent colours with glossy finish

49 verde / tampografia 35 x 7 mm
49 green / pad printing 35 x 7 mm



39 52 53 45 51 55



47 44 40

Icon

IC400 – FROST

colori trasparenti con finitura satinata
transparent colours with matt finish

44 blu / tampografia 35 x 7 mm
44 blue / pad printing 35 x 7 mm



39 52 53 45



55 49 47



40

51 viola / serigrafia 40 x 30 mm
51 violet / screen printing 40 x 30 mm

Icon

IC400 – MATT AL

colori coprenti con finitura satinata,
punta verniciata in colore alluminio
solid colours with matt finish,
aluminium painted finish tip

71 viola chiaro / tampografia 35 x 7 mm
71 light violet / pad printing 35 x 7 mm

18 arancio / tampografia 35 x 7 mm
18 orange / pad printing 35 x 7 mm



Il fusto e la clip sono progettati per offrire ampi spazi di personalizzazione e rispondere alle esigenze di ogni cliente.

The barrel and clip have been designed to provide ample space for personalisation to meet each customer's requirements.

04 nero / serigrafia 40 x 30 mm
04 black / screen printing 40 x 30 mm



27 ottanio / tampografia 35 x 7 mm
27 octan green / pad printing 35 x 7 mm



Icon

IC400 – C CR

colori coprenti con finitura lucida, punta cromata
solid colours with glossy finish, chromed tip



61 magenta / tampografia 35 x 7 mm
61 magenta / pad printing 35 x 7 mm



70 03 18 15 74 60

01 bianco / tampografia 45 x 9 mm
01 white / pad printing 45 x 9 mm



71 25



72



73 marrone / tampografia 35 x 7 mm
73 brown / pad printing 35 x 7 mm



79 09



75 verde scuro / tampografia 35 x 7 mm
75 dark green / pad printing 35 x 7 mm



27 64 12 22 04

Icon IC400 – FROST AL

colori trasparenti con finitura satinata,
punta verniciata in colore alluminio
transparent colours, matt finish,
aluminium painted finish tip



40 grigio / tampografia 35 x 7 mm
40 grey / pad printing 35 x 7 mm

53 arancio / tampografia 35 x 7 mm
53 orange / pad printing 35 x 7 mm

serigrafia 40 x 30 mm
screen printing 40 x 30 mm

39

52

45

51

55

49

47

44

Icon IC400 – 30 CR

colori trasparenti con finitura
lucida, punta cromata
transparent colours with
glossy finish, chromed tip



45 rosso / tampografia 35 x 7 mm
45 red / pad printing 35 x 7 mm

47 acquamarina / tampografia 35 x 7 mm
47 aquamarine / pad printing 35 x 7 mm

39

52

53

51

55

49

44

40

Icon

IC400 – C GOLD

colori coprenti con finitura lucida, punta dorata
solid colours with glossy finish, gilded tip

04 nero / serigrafia 40 x 30 mm
04 black / screen printing 40 x 30 mm



Icon

IC400 – MET AL

fusto e cappuccio verniciati in colori metallizzati,
punta verniciata in colore alluminio
metallic colours painted finish barrel and cap,
aluminium painted finish tip

Esclusivi colori metallizzati ad alta resistenza.

Exclusive *high strength* metallic colours.

alluminio / tampografia 35 x 7 mm
aluminium / pad printing 35 x 7 mm



83 rame / tampografia 35 x 7 mm
83 copper / pad printing 35 x 7 mm

IC400 – AL CR

fusto e cappuccio verniciati
in colore alluminio,
punta cromata
aluminium painted finish
barrel and cap, chromed tip



Tag green

obiettivo: sicurezza totale
objective: total safety



**Il design sposa
la sicurezza e rispetta
l'ambiente.**

*Design that combines safety
and environment friendliness.*

“Realizzata con plastica idonea alla produzione dei giocattoli.”

“Made from a special plastic, suitable for use in toy manufacture.”



Guarda al futuro

Prodotta con plastica idonea all'utilizzo nei giocattoli (direttiva europea EN 71 - 03 e direttiva americana FDA).

Looking to the future

Made of plastic suitable for toy manufacture (according to European standard EN 71-03 and U.S. FDA regulations).



Antibacterial

La plastica è antibatterica, grazie ad uno speciale additivo che sprigiona ioni d'argento impedendo ai batteri di depositarsi sulle superfici della penna.

Antibacterial

It is made of antibacterial plastic containing a special additive which releases silver ions that prevent bacteria from colonising the surface of the pen.

LOVING NATURE

Antibatterica, atossica e sostenibile. Una penna che dura ama la natura.

Antibacterial, non-toxic and sustainable. A pen that lasts is a pen that loves nature.



Vicina all'ambiente

Realizzata con materiali atossici, è stata progettata per durare a lungo nel tempo. Una penna che dura di più inquina di meno perchè rimane a lungo nelle nostre mani, massimizzando la diffusione del logo o del messaggio che porta con sé.

Nature friendly

Made of non-toxic plastics, it has been designed to have a long life and to minimise the risk of harmful substances being released into the environment. Using a pen for as long as possible helps to reduce pollution and enables us to give full expression to the concept of promotion.



Green Chemical

Non contiene: diossina, ftalati, bisfenolo A, antimonio, arsenico, bario, cadmio, cromo, mercurio e piombo ed è conforme alle normative RoHS e REACH. Bifenili polibromurati (PBB), eteri di difenile (PBDE) e deca BDE sono completamente assenti.

Green Chemical

It does not contain dioxin, phthalates, bisphenol A, antimony, arsenic, barium, cadmium, chrome, mercury, lead, polybrominated biphenyls (PBBs), polybrominated diphenyl ethers (PBDEs) or deca-BDE, and conforms to RoHS and REACH directives.



Buona davvero

Le plastiche utilizzate sono conformi alla normativa europea e americana FDA per il contatto alimentare.

Really safe

The plastics employed are compliant with European and American FDA food contact regulations.



Conforme alle regole

La plastica non risulta pericolosa per il CLP (classification, labeling and packaging).

CLP compliant

It is rated as non hazardous pursuant to the Regulation on Classification, Labelling and Packaging.

Tag green

informazioni tecniche

technical information

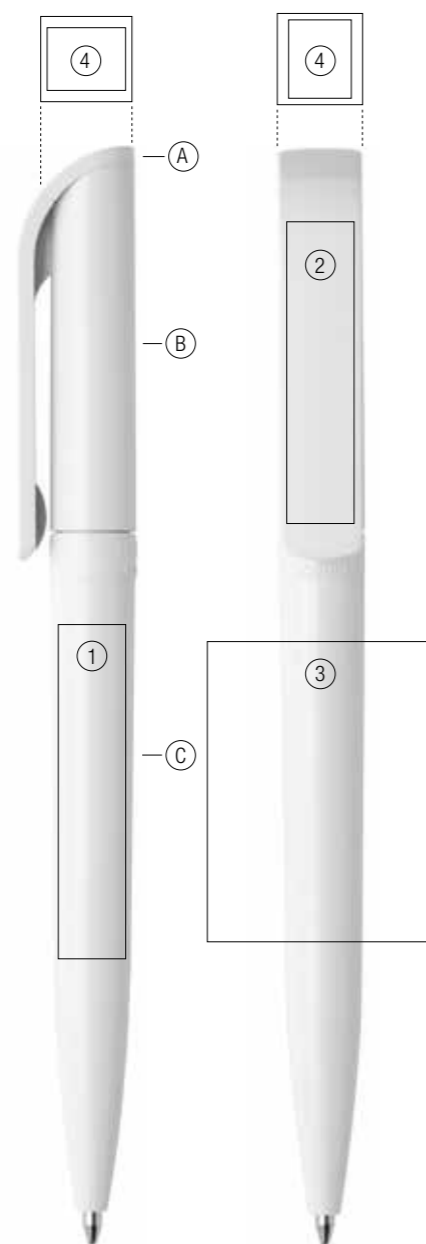

È possibile combinare particolari di colori diversi della stessa versione (o codice), oppure abbinare elementi di versioni differenti.

You can combine differently coloured parts from the same version (or code number), or elements from different versions.

- A tassello
- B clip
- C fusto
- A plug
- B clip
- C barrel

1/5

CARATTERISTICHE

- meccanismo a rotazione
- realizzata in plastica ABS speciale, ad alta resistenza, atossica e certificata per l'utilizzo nei giocattoli
- antibatterica
- refill X-20, inchiostro blu e nero
- disponibile con superfici lucide

FEATURES

- twist-action
- made of non-toxic, highly resistant special ABS plastic certified for use in toy manufacture
- antibacterial
- X20 refill, blue and black ink
- available in glossy finish

2/5

AREA STAMPABILE

- 1 tampografia 45 x 9 mm
- 2 tampografia 40 x 9 mm
- 3 serigrafia 40 x 30 mm
- 4 tampografia 8 x 10 mm

PRINT AREA

- 1 pad printing 45 x 9 mm
- 2 pad printing 40 x 9 mm
- 3 screen printing 40 x 30 mm
- 4 pad printing 8 x 10 mm

3/5

FUSTO

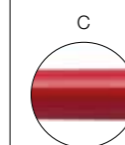

4/5

TASSELLO

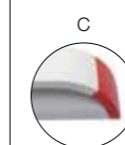

5/5

COLORAZIONI

- colori coprenti speciali



PLUG

COLOURS

- special solid colours

Per Tag Green è disponibile l'astuccio my-case in cartoncino FSC.

The FSC cardboard pen box my-case is available for the Tag Green.



Tag green TA2 – B

fusto e clip in colore bianco coprente, tassello superiore in colori coprenti, finiture lucide
solid white colour barrel and clip,
solid colours upper plug, glossy finishes

La plastica Green Chemical sprigiona ioni d'argento che svolgono una **funzione antibatterica.**

*Green Chemical plastic releases silver ions that have an **anti-bacterial function.***

01 bianco / tampografia 40 x 9 mm
01 white / pad printing 40 x 9 mm

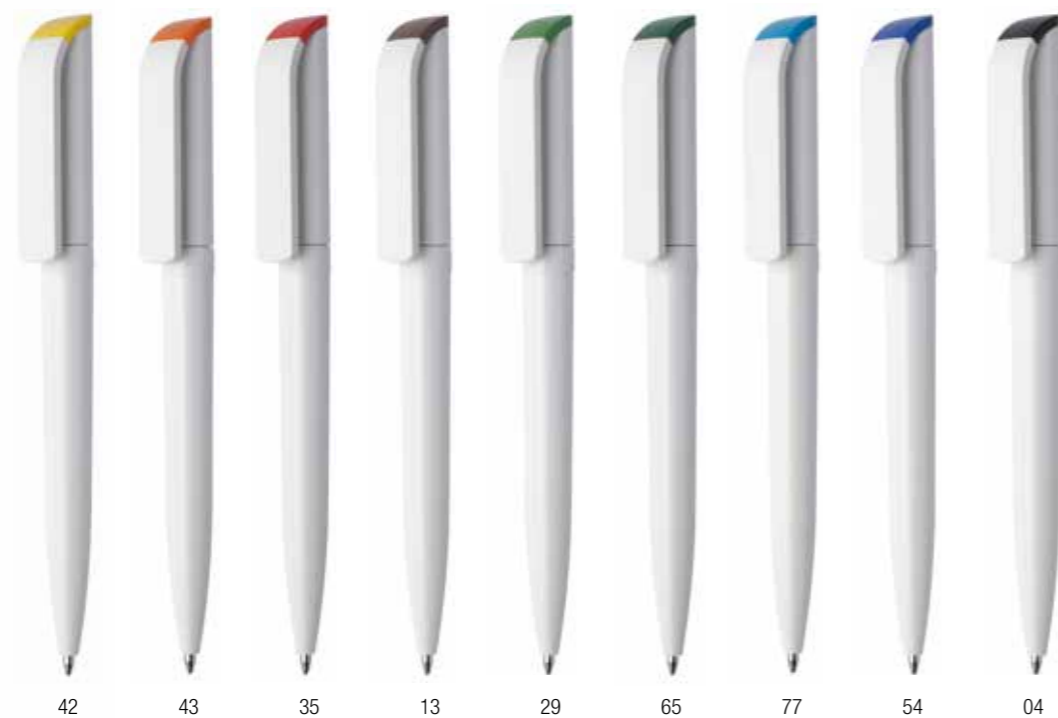

Tag green TA2 – BC

fusto e tassello superiore in colore bianco coprente, clip in colori coprenti, finiture lucide
solid white colour barrel and upper plug,
solid colours clip, glossy finishes

54 blu / tampografia 40 x 9 mm
54 blue / pad printing 40 x 9 mm

29 verde / tampografia 40 x 9 mm
29 green / pad printing 40 x 9 mm



Icon green

nel rispetto dell'uomo e della natura
people and environment friendly



**Testimone di un
messaggio destinato
a durare nel tempo.**

Testimony of an enduring message.

“Un significativo passo avanti nella sicurezza della plastica.”

“A significant step forward toward the use of safe plastic.”



Vicina all'ambiente

Realizzata con materiali atossici, è stata progettata per durare a lungo nel tempo. **Una penna che dura di più inquina di meno** perchè rimane a lungo nelle nostre mani, massimizzando la diffusione del logo o del messaggio che porta con sé.

Nature friendly

Made of non-toxic plastics, it has been designed to have a long life and to minimise the risk of harmful substances being released into the environment. **Using a pen for as long as possible helps to reduce pollution** and enables us to give full expression to the concept of promotion.



Green Chemical

Non contiene: diossina, ftalati, bisfenolo A, antimonio, arsenico, bario, cadmio, cromo, mercurio e piombo ed è **conforme alle normative RoHS e REACH**. Bifenili polibromurati (PBB), eteri di difenile (PBDE) e deca BDE **sono completamente assenti**.

Green Chemical

It does not contain dioxin, phthalates, bisphenol A, antimony, arsenic, barium, cadmium, chrome, mercury, lead, polybrominated biphenyls (PBBs), polybrominated diphenyl ethers (PBDEs) or deca-BDE, and **conforms to RoHS and REACH directives**.

LOVING NATURE

Antibatterica, atossica e sostenibile. Una penna che dura ama la natura.

Antibacterial, non-toxic and sustainable. A pen that lasts is a pen that loves nature.



Guarda al futuro

Prodotta con plastica idonea all'utilizzo nei giocattoli (direttiva europea EN 71 - 03 e direttiva americana FDA).

Looking to the future

Made of plastic suitable for toy manufacture (according to European standard EN 71-03 and U.S. FDA regulations).



Antibacterial

La plastica è antibatterica, grazie ad uno speciale additivo che sprigiona ioni d'argento impedendo ai batteri di depositarsi sulle superfici della penna.

Antibacterial

It is made of antibacterial plastic containing a special additive which releases silver ions that prevent bacteria from colonising the surface of the pen.



Buona davvero

Le plastiche utilizzate sono **conformi alla normativa europea e americana FDA per il contatto alimentare**.

Really safe

The plastics employed are compliant with European and American FDA food contact regulations.



Conforme alle regole

La plastica non risulta pericolosa per il CLP (classification, labeling and packaging).

CLP compliant

It is rated as **non hazardous** pursuant to the Regulation on Classification, Labelling and Packaging.



Icon green

informazioni tecniche

technical information

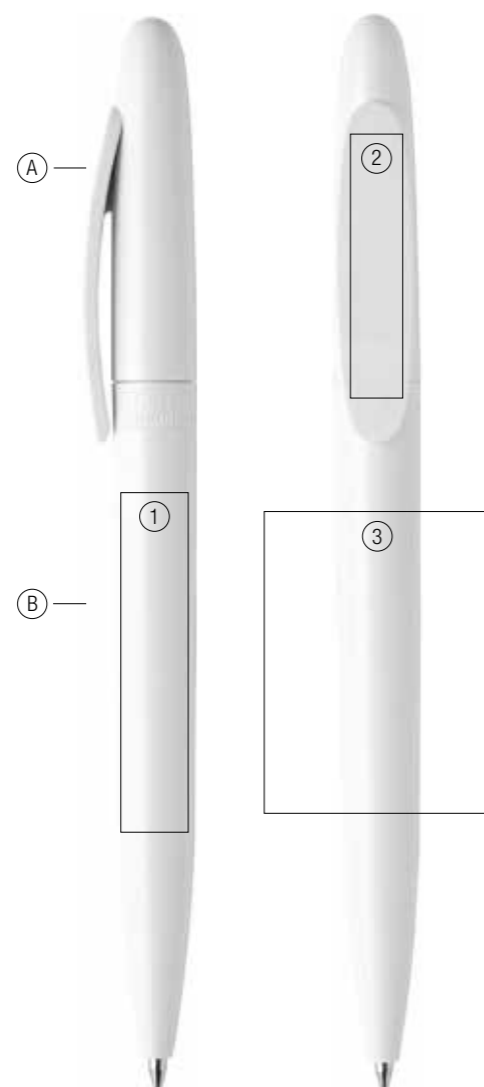

È possibile combinare particolari di colori diversi della stessa versione (o codice), oppure abbinare elementi di versioni differenti.

You can combine differently coloured parts from the same version (or code number), or elements from different versions.

- A cappuccio
- A cap
- B fusto
- B barrel

1/5

CARATTERISTICHE

- meccanismo a rotazione
- realizzata in plastica ABS speciale, ad alta resistenza, atossica e certificata per l'utilizzo nei giocattoli
- antibatterica
- refill X20, inchiostro blu e nero
- disponibile con superfici lucide

FEATURES

- twist-action
- made of non-toxic, highly resistant special ABS plastic certified for use in toy manufacture
- antibacterial
- X20 refill, blue and black ink
- available in glossy finish

2/5

AREA STAMPABILE

- 1 tampografia 45 x 9 mm
- 2 tampografia 35 x 7 mm
- 3 serigrafia 40 x 30 mm

PRINT AREA

- 1 pad printing 45 x 9 mm
- 2 pad printing 35 x 7 mm
- 3 screen printing 40 x 30 mm

3/5

FUSTO

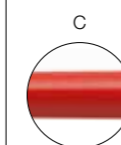

4/5

CAPPUCCIO

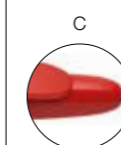

5/5

COLORAZIONI

- colori coprenti speciali



BARREL

CAP

COLOURS

- special solid colours

Per Icon Green è disponibile lo speciale astuccio in cartoncino FSC, dotato di foglietto informativo che spiega le caratteristiche tecniche della penna.

The special FSC cardboard box is available for the Icon Green. It comes with an information sheet explaining the pen's technical features.



Icon green IG2 – BC

fusto in colore bianco coprente,
cappuccio in colori coprenti, finiture lucide
solid white colour barrel, solid colours cap,
glossy finishes

35 rosso / tampografia 35 x 7 mm
35 red / pad printing 35 x 7 mm



42

43



**Realizzata con una
plastica speciale idonea
alla produzione
di giocattoli.**

*Made of special plastic used
to manufacture children's toys.*



29 verde / tampografia 35 x 7 mm
29 green / pad printing 35 x 7 mm



13



65



54



04

Icon green IG2 – C

colori solidi con finitura lucida
solid colours with glossy finish

65 verde scuro / tampografia 35 x 7 mm
65 dark green / pad printing 35 x 7 mm



01 bianco / tampografia 35 x 7 mm
01 white / pad printing 35 x 7 mm



70



42



43



35



13



29



54



04

3/5

Ethic

eleganza e flessibilità
elegance and flexibility



**Costruita a misura
di cliente.**

Tailored to the customer's requirements.

Ethic

informazioni tecniche

technical information



- | | |
|-------------|-------------|
| Ⓐ tappino | Ⓐ small cap |
| Ⓑ cappuccio | Ⓑ cap |
| Ⓒ anelli | Ⓒ rings |
| Ⓓ fusto | Ⓓ barrel |
| Ⓔ punta | Ⓔ tip |

È possibile combinare particolari di colori diversi della stessa versione (o codice), oppure abbinare elementi di versioni differenti.

You can combine differently coloured parts from the same version (or code number), or elements from different versions.

1/4

CARATTERISTICHE

- meccanismo a rotazione
- realizzata in plastica ABS, atossica e ad alta resistenza
- clip in metallo, con finitura cromata, dorata o verniciata color alluminio
- la cromatura e la doratura delle parti in ABS sono ottenute con un trattamento galvanico
- refill Jumbo, inchiostro blu e nero
- disponibile con superfici lucide o verniciate in colori metallizzati o alluminio

FEATURES

- twist-action
- made of non-toxic, highly resistant ABS plastic
- metal clip with chrome, gilded or aluminium painted finish
- galvanic process used to chrome or to gild ABS parts
- Jumbo refill, blue and black ink
- available in glossy and metallic or aluminium painted finish

2/4

AREA STAMPABILE

- ① tampografia 30 x 8 mm
- ② serigrafia 45 x 30 mm
- ③ tampografia 55 x 9,5 mm

PRINT AREA

- ① pad printing 30 x 8 mm
- ② screen printing 45 x 30 mm
- ③ pad printing 55 x 9,5 mm

3/4

FUSTO

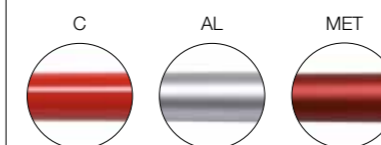

BARREL

PUNTA E ANELLI

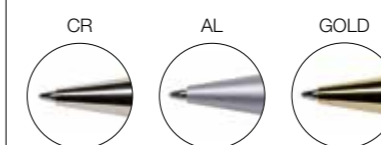

TIP AND RINGS

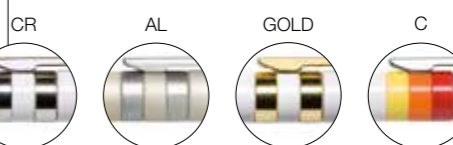

4/4

COLORAZIONI

- coprenti
- 01 70 03 18 15 74 25 09 75
- vernici metallizzate
- 91 92 83 85 81 82 89 94 95
- trattamento galvanico
- ●

COLOURS

- solid
- 27 12 22 04
- metallic paintings
- 96 ●
- galvanic process

Ethic

ET900 – MULTICOLOUR

colori coprenti con finitura lucida,
clip in metallo cromato, punta cromata
solid colours with glossy finish, metal
chrome finish clip, chromed tip

**Pensata per durare
oltre le mode del
momento, come il
messaggio che deve
trasmettere.**

*Designed to outlast passing fashions,
like the message it conveys.*



Ethic

ET900 – FLAG

colori coprenti con finitura lucida,
clip in metallo cromato, punta cromata
solid colours with glossy finish, metal
chrome finish clip, chromed tip



ET900 – C FLAG

colori coprenti con finitura lucida,
clip in metallo cromato, punta cromata
solid colours with glossy finish, metal
chrome finish clip, chromed tip



Ethic

ET900 – B

colori coprenti con finitura lucida,
clip in metallo cromato, punta cromata
solid colours with glossy finish, metal
chrome finish clip, chromed tip

**Punta, fusto, cappuccio, tappino
e 3 anelli disponibili in una ricca
gamma di colori: più di 300
milioni di combinazioni possibili!**

*Tip, barrel, cap, push-button and 3 rings
available in a vast range of colours: more
than 300 million combinations possible!*



03



03

15



15

74



74

25



25

09



09

12



12

22



22

18



18 arancio / tampografia 55 x 9,5 mm
18 orange / pad printing 55 x 9,5 mm

04



04 nero / tampografia 55 x 9,5 mm
04 black / pad printing 55 x 9,5 mm

Ethic

ET900 – BC

colori coprenti con finitura lucida,
clip in metallo cromato, due anelli,
punta cromata e tappino bianco
solid colours with glossy finish,
metal chrome finish clip, white
top, chromed tip and two rings



01



15 rosso / tampografia 30 x 8 mm
15 red / pad printing 30 x 8 mm

serigrafia 45 x 30 mm
screen printing 45 x 30 mm

01



70

01



03

01



18

01



74

01



09

01



27

01



12

01



22

01



04

Ethic

ET900 – C CR

colori coprenti con finitura lucida, clip in metallo cromato, due anelli, punta e tappino cromati
solid colours with glossy finish, metal chrome finish clip, chromed tip, top and two rings



03 giallo / tampografia 55 x 9,5 mm
03 yellow / pad printing 55 x 9,5 mm

74 bordeaux / tampografia 55 x 9,5 mm
74 burgundy / pad printing 55 x 9,5 mm

ET900 – C GOLD

colori coprenti con finitura lucida, clip in metallo dorato, due anelli, punta e tappino dorati
solid colours with glossy finish, gilded metal finish clip, gilded tip, top and two rings

I dettagli, cromati o dorati, ne esaltano l'eleganza.

The chrome or gilded details enhance the pen's elegance.



01 bianco / serigrafia 45 x 30 mm
01 white / screen printing 45 x 30 mm

Ethic

ET900 – AL

fusto, cappuccio e anello centrale verniciati in colore alluminio, due anelli e tappino in colore coprente con finitura lucida, clip in metallo cromato, punta cromata
aluminium painted finish barrel, cap and central ring, solid colour two rings and top with glossy finish, metal chrome finish clip, chromed tip



Ethic

ET900 – AL CR

fusto, cappuccio e anello centrale verniciati in colore alluminio, clip in metallo cromato, due anelli, tappino e punta cromati
aluminium painted finish barrel, cap and central ring, metal chrome finish clip, chromed tip, top, and two rings

chrome



**Design raffinato
e flessibile, per i brand
più esigenti.**

*Refined, flexible design for
the most demanding brands.*

09



IT

Ethic

ET900 – MET CR

fusto, cappuccio e anello centrale verniciati in colori metallizzati, clip in metallo cromato, due anelli, tappino e punta cromati
 metallic colour painted finish barrel, cap and central ring, metal chrome finish clip, chromed tip, top and two rings



Ethic

ET900 – MET AL

fusto, cappuccio e anello centrale verniciati in colori metallizzati, clip in metallo verniciato in colore alluminio, due anelli, tappino e punta verniciati in colore alluminio
 metallic colour painted finish barrel, cap and central ring, metal aluminium painted finish clip, aluminium painted finish tip, top and two rings



Next

la forma che verrà
the shape for the future



**Scattante e dinamica:
l'accelerazione positiva
per ogni brand.**

*Sleek, dynamic lines, able to boost
the visibility and identity of every brand.*

Next
informazioni
tecniche
technical
information

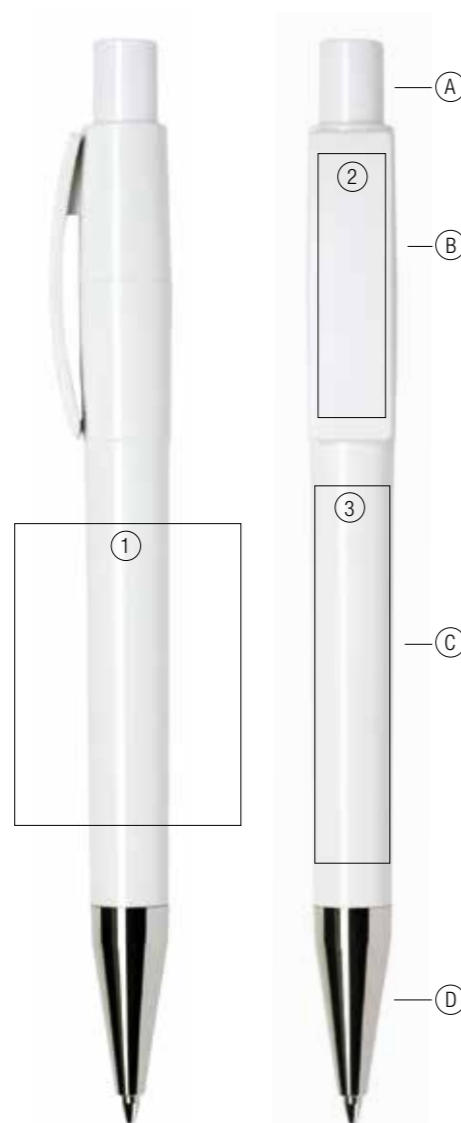

- | | |
|-----------|---------------|
| Ⓐ tappino | Ⓐ push-button |
| Ⓑ clip | Ⓑ clip |
| Ⓒ fusto | Ⓒ barrel |
| Ⓓ punta | Ⓓ tip |

È possibile combinare particolari di colori diversi della stessa versione (o codice), oppure abbinare elementi di versioni differenti.

You can combine differently coloured parts from the same version (or code number), or elements from different versions.

1/5

CARATTERISTICHE

- meccanismo a scatto, con molla di ritorno
- tappino ventilato
- realizzata in plastica ABS, atossica e ad alta resistenza
- refill Jumbo, inchiostro blu e nero
- il fusto è disponibile con superfici lucide, satinare, gommate o verniciate con colori metallizzati o alluminio
- la cromatura della punta in ABS è ottenuta con trattamento galvanico
- le versioni NX 400 - GOM C CR e NX 400 - GOM AL sono stampabili solo sulla clip

FEATURES

- retractable with return spring
- ventilated push-button
- made of non-toxic, highly resistant ABS plastic
- Jumbo refill, blue and black ink
- the barrel is available in glossy, matt, rubberised and metallic or aluminium painted finish
- galvanic process used to chrome the ABS tip
- the NX 400 - GOM C CR and NX 400 - GOM AL versions are only printable on the clip

2/5

AREA STAMPABILE

- ① serigrafia 40 x 30 mm
- ② tampografia 35 x 9 mm
- ③ tampografia 50 x 10 mm

PRINT AREA

- ① screen printing 40 x 30 mm
- ② pad printing 35 x 9 mm
- ③ pad printing 50 x 10 mm

3/5

FUSTO



BARREL

4/5

PUNTA E TAPPINO

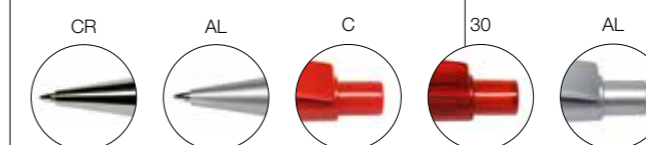

TIP AND PUSH-BUTTON

5/5

COLORAZIONI

- coprenti
- ① 01 70 03 18 15 74 09 12 22 04
- trasparenti
- ② 39 52 53 45 51 55 49 47 44 40
- vernici metallizzate
- 92 83 85 94 95 96
- trattamento galvanico

COLOURS

- solid
- transparent
- metallic paintings
- galvanic process

Next

NX400 – C CR

colori coprenti con finitura lucida, punta cromata
solid colours with glossy finish, chromed tip



70 03 18 15 74 09 12 22

04 nero / tampografia 50 x 10 mm
04 black / pad printing 50 x 10 mm



01 bianco / tampografia 50 x 10 mm
01 white / pad printing 50 x 10 mm

Next

NX400 – 30 CR

colori trasparenti con finitura lucida, punta cromata
transparent colours with glossy finish, chromed tip



39 52 53 45 55 49 44 40

47 acquamarina / tampografia 35 x 9 mm
47 aquamarine / pad printing 35 x 9 mm



51 viola / tampografia 35 x 9 mm
51 violet / pad printing 35 x 9 mm

Next

NX400 – FROST AL

fusto colore trasparente con finitura satinata, clip, tappino e punta verniciati in colore alluminio
transparent colour barrel with matt finish, aluminium painted finish clip, push-button and tip

La clip: uno schermo su cui trasmettere l'immagine di un brand.

The clip: a screen for conveying brand image.

44 blu / tampografia 35 x 9 mm
44 blue / pad printing 35 x 9 mm

49 verde / tampografia 35 x 9 mm
49 green / pad printing 35 x 9 mm



Next

NX400 – MET AL

fusto verniciato in colori metallizzati, clip, tappino e punta verniciati in colore alluminio
metallic colours painted finish barrel, aluminium painted finish clip, push-button and tip

NX400 – AL CR

verniciatura in colore alluminio, punta cromata
aluminium painted finish, chromed tip

alluminio / tampografia 35 x 9 mm
aluminium / pad printing 35 x 9 mm

85 rosso / tampografia 50 x 10 mm
85 red / pad printing 50 x 10 mm



Next

NX400 – GOM C CR

fusto in colore coprente gommato, clip e tappino
in colori coprenti con finitura lucida, punta cromata
solid colour barrel with rubber finish, solid colour
clip and push-button with glossy finish, chromed tip



74 bordeaux / tampografia 35 x 9 mm
74 burgundy / pad printing 35 x 9 mm

03

18

15

09

12 azzurro / tampografia 35 x 9 mm
12 light blue / pad printing 35 x 9 mm

22

04

Next

NX400 – GOM AL

fusto in colore coprente gommato, clip,
tappino e punta verniciati in colore alluminio
solid colour barrel with rubber finish, aluminium
painted finish clip, push-button and tip



03 giallo / tampografia 35 x 9 mm
03 yellow / pad printing 35 x 9 mm

18

15

74



09 verde / tampografia 35 x 9 mm
09 green / pad printing 35 x 9 mm

12

22

04

**Il tappino è ventilato
per garantire
sufficiente passaggio
di aria in caso
di ingestione.**

*The ventilated push-button
ensures sufficient airflow
if inadvertently swallowed.*

Pixel

il design ad alta definizione
high resolution design

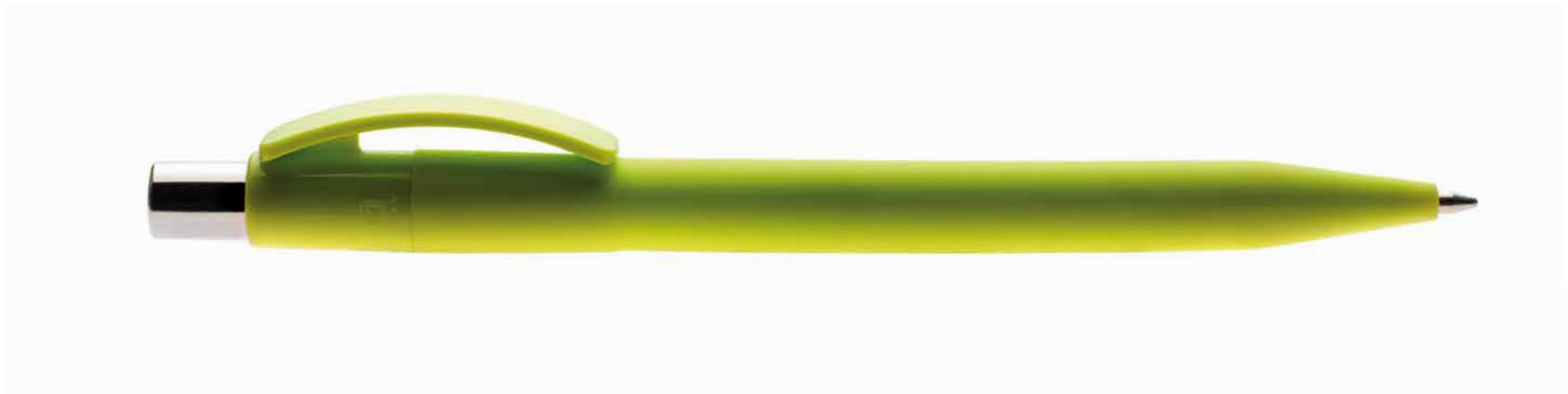

**Sintesi dello stile
contemporaneo.**

A synthesis of contemporary style.

Pixel
informazioni
tecniche
*technical
information*

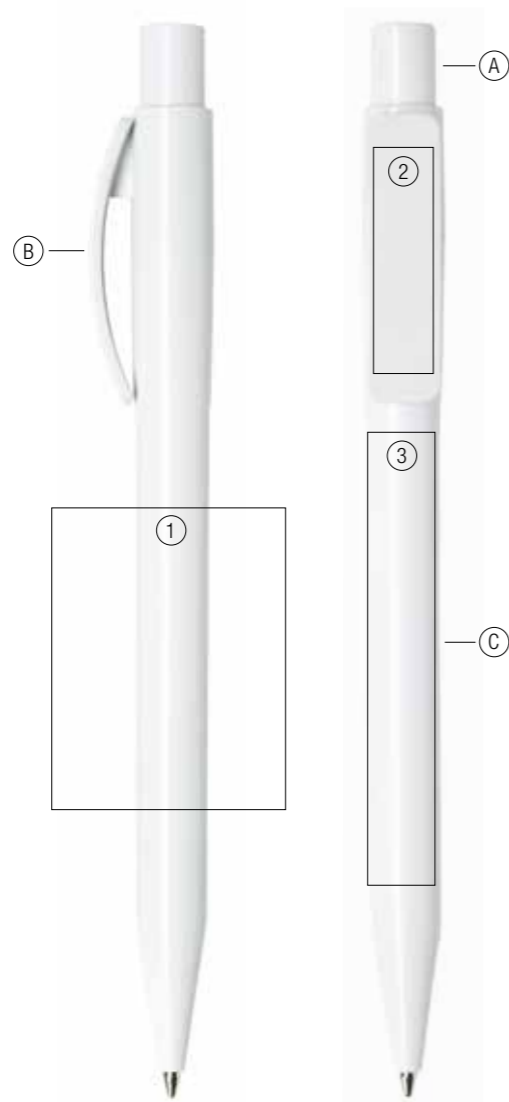

**Vai su maxema.com
per scegliere i tuoi
colori preferiti.**

*Go to maxema.com to choose
your favourite colours.*

- Ⓐ tappino Ⓐ push-button
- Ⓑ clip Ⓑ clip
- Ⓒ fusto Ⓒ barrel

1/5

CARATTERISTICHE

- meccanismo a scatto
- tappino ventilato
- realizzata in plastica ABS, atossica e ad alta resistenza
- refill X 20, inchiostro blu e nero
- il fusto è disponibile con superfici lucide, satinare o gommate
- la cromatura del tappino in ABS è ottenuta con trattamento galvanico
- le versioni PX 40 - GOM C CR e PX 40 - GOM 30 CR sono stampabili solo sulla clip

FEATURES

- retractable
- ventilated push-button
- made of non-toxic, highly resistant ABS plastic
- X-20 refill, blue and black ink
- the barrel is available in glossy, matt or rubberised finish
- galvanic process used to chrome the ABS push-button
- the PX 40 - GOM C CR and PX 40 - GOM 30 CR versions are only printable on the clip

2/5

AREA STAMPABILE

- ① serigrafia 40 x 31 mm
- ② tampografia 30 x 8 mm
- ③ tampografia 60 x 9 mm

PRINT AREA

- ① screen printing 40 x 31 mm
- ② pad printing 30 x 8 mm
- ③ pad printing 60 x 9 mm

3/5

FUSTO

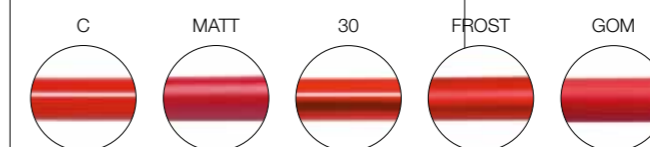

BARREL

4/5

TAPPINO

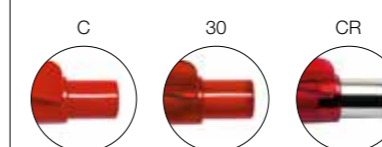

PUSH-BUTTON

5/5

COLORAZIONI

- coprenti
- ① 01 70 03 18 15 74 60 61 71
- trasparenti
- ① 39 52 53 45 41 51 55 49 47
- trattamento galvanico

COLOURS

- solid
- ① 25 73 79 09 75 26 27 64 77 12 22 05 04
- transparent
- ① 44 40 50
- galvanic process

Pixel PX40 – B

fusto e tappino in colore bianco coprente,
clip in colori coprenti, finiture lucide
solid white colour barrel and push-button,
solid colours clip, glossy finishes

22 blu / tampografia 30 x 8 mm
22 blue / pad printing 30 x 8 mm

74 bordeaux / tampografia 30 x 8 mm
74 burgundy / pad printing 30 x 8 mm



Pixel PX40 – C

colori coprenti con finitura lucida
solid colours with glossy finish

04 nero / tampografia 30 x 8 mm
04 black / pad printing 30 x 8 mm

09 verde / tampografia 30 x 8 mm
09 green / pad printing 30 x 8 mm



Pixel

PX40 – MATT CR

fusto in colore coprente con finitura satinata,
clip in colore coprente lucido, tappino cromato
solid colour barrel with matt finish, solid glossy
colour clip, chromed push-button

NEW

73 marrone / tampografia 30 x 8 mm
73 brown / pad printing 30 x 8 mm

26 acquamarina / tampografia 30 x 8 mm
26 aquamarine / pad printing 30 x 8 mm

03 giallo / tampografia 30 x 8 mm
03 yellow / pad printing 30 x 8 mm

64 azzurro pastello / tampografia 60 x 9 mm
64 pastel blue / pad printing 60 x 9 mm

Pixel

PX40 – B 30

fusto colore bianco coprente lucido, clip e tappino in colori trasparenti con finitura lucida
solid glossy white colour barrel, transparent colour clip and push button with glossy finish

51 viola / tampografia 30 x 8 mm
51 violet / pad printing 30 x 8 mm



40 grigio / tampografia 30 x 8 mm
40 grey / pad printing 30 x 8 mm



Pixel

PX40 – 30

colori trasparenti con finitura lucida
transparent colours with glossy finish

Design dai tratti essenziali: uno strumento grintoso per brand dinamici.

*Design with basic features:
a feisty pen for dynamic brands.*

47 acquamarina / tampografia 30 x 8 mm
47 aquamarine / pad printing 30 x 8 mm



45 rosso / tampografia 30 x 8 mm
45 red / pad printing 30 x 8 mm



Pixel

PX40 – FROST NEUTRAL

colori trasparenti, fusto con finitura satinata,
clip e tappino con finitura lucida
transparent colours, matt finish barrel,
glossy finish clip and push-button

**Il tappino ventilato
è conforme alle
normative CEE sui
piccoli componenti.**

*The ventilated push-button is compliant
with EU laws for small components.*

55 viola scuro / tampografia 30 x 8 mm
55 dark violet / pad printing 30 x 8 mm



53 arancio / tampografia 30 x 8 mm
53 orange / pad printing 30 x 8 mm

Pixel

PX40 – FROST

colori trasparenti, fusto con finitura satinata,
clip e tappino con finitura lucida
transparent colours, matt finish barrel,
glossy finish clip and push-button

44 blu / tampografia 30 x 8 mm
44 blue / pad printing 30 x 8 mm



51 viola / tampografia 30 x 8 mm
51 violet / pad printing 30 x 8 mm

tampografia 60 x 9 mm
pad printing 60 x 9 mm

Pixel

PX40 – GOM C CR

fusto in colore coprente gommato, clip in colore
coprente con finitura lucida, tappino cromato
solid colour barrel with rubber finish, solid colour
clip with glossy finish, chromed push-button

04 nero / tampografia 30 x 8 mm
04 black / pad printing 30 x 8 mm

15 rosso / tampografia 30 x 8 mm
15 red / pad printing 30 x 8 mm



18



74



61



25



79



09



22



Pixel

PX40 – GOM 30 CR

fusto in colore coprente gommato, clip in colore
trasparente con finitura lucida, tappino cromato
solid colour barrel with rubber finish, transparent
colour clip with glossy finish, chromed push-button

47 acquamarina / tampografia 30 x 8 mm
47 aquamarine / pad printing 30 x 8 mm



53



45



41 magenta / tampografia 30 x 8 mm
41 magenta / pad printing 30 x 8 mm



55



49



44



50

4/5

Bay

disinvolta e accattivante
casual and attractive



**Attrae per
la sua semplicità.**

Draws attention for its simplicity.

Bay
informazioni
tecniche
*technical
information*

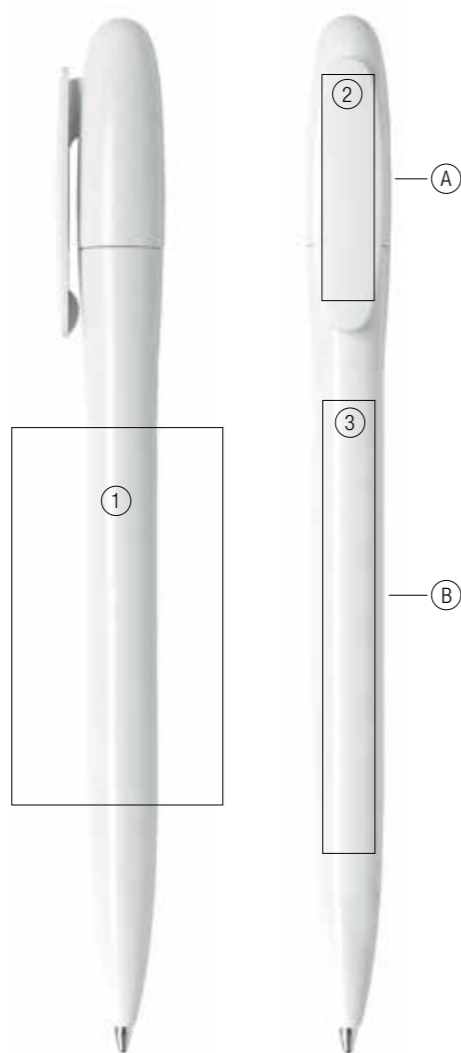

**Vai su maxema.com
per scegliere i tuoi
colori preferiti.**

*Go to maxema.com to choose
your favourite colours.*

- A cappuccio
- A cap
- B fusto
- B barrel

1/4

CARATTERISTICHE

- meccanismo a rotazione
- realizzata in plastica ABS, atossica e ad alta resistenza
- refill X-20, inchiostro blu e nero
- disponibile con superfici lucide o satinare

FEATURES

- twist-action
- made of non-toxic, highly resistant ABS plastic
- X-20 refill, blue and black ink
- available in glossy or matt finish

2/4

AREA STAMPABILE

- 1 serigrafia 50 x 28 mm
- 2 tampografia 30 x 7 mm
- 3 tampografia 60 x 7 mm

PRINT AREA

- 1 screen printing 50 x 28 mm
- 2 pad printing 30 x 7 mm
- 3 pad printing 60 x 7 mm

3/4

FUSTO

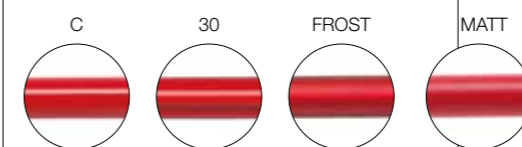

BARREL

CAPPUCCIO

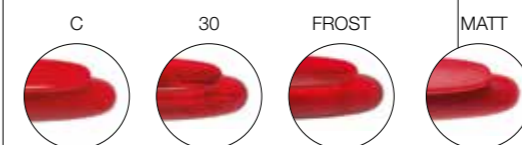

CAP

4/4

COLORAZIONI

- coprenti
- 01 70 03 18 15 74 60 61 71
- trasparenti
- 39 52 53 45 51 55 49 47 44

COLOURS

- solid
- 25 73 79 09 75 26 27 64 77 12 22 05 04
- transparent
- 40

Bay B500 – MATT BC

fusto in colore bianco coprente, cappuccio
in colori coprenti, finiture satinare
solid white colour barrel, solid colours cap,
matt finishes

NEW



60 rosa / tampografia 30 x 7 mm
60 pink / pad printing 30 x 7 mm



75 verde scuro / tampografia 30 x 7 mm
75 dark green / pad printing 30 x 7 mm

tampografia 60 x 7 mm
pad printing 60 x 7 mm

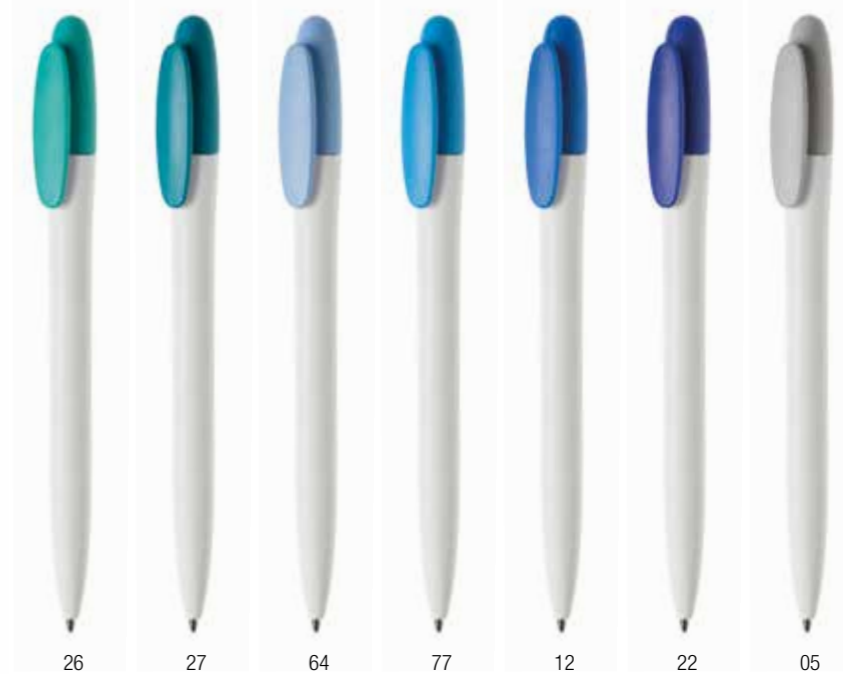

04 nero / tampografia 60 x 7 mm
04 black / pad printing 60 x 7 mm



AIR NEW ZEALAND

Bay

B500 – MATT

colori coprenti con finitura satinata
solid colours with matt finish

73 marrone / tampografia 60 x 7 mm
73 brown / pad printing 60 x 7 mm



**Effetto satinato:
raffinata delicatezza
declinabile in 22 colori.**

Delicately refined matt finish in 22 colours.



70 03 18 15 74 60 61 71 25

01 bianco / tampografia 30 x 7 mm
01 white / pad printing 30 x 7 mm



79 09 75 26



64 77 12 22 05 04

27 ottanio / tampografia 30 x 7 mm
27 octan green / pad printing 30 x 7 mm

Bay B500 – BC

fusto in colore bianco coprente,
cappuccio in colori coprenti, finiture lucide
solid white colour barrel, solid colours cap,
glossy finishes

22 blu / tampografia 60 x 7 mm
22 blue / pad printing 60 x 7 mm



Bay B500 – C

colori coprenti con finitura lucida
solid colours with glossy finish

04 nero / tampografia 30 x 7 mm
04 black / pad printing 30 x 7 mm



Bay B500 – 30

colori trasparenti con finitura lucida
transparent colours with glossy finish

47 acquamarina / tampografia 30 x 7 mm
47 aquamarine / pad printing 30 x 7 mm



39 52 53



51 55 49



44 40

45 rosso / tampografia 30 x 7 mm
45 red / pad printing 30 x 7 mm



Bay B500 – FROST

colori trasparenti con finitura satinata
transparent colours with matt finish

55 viola scuro / tampografia 30 x 7 mm
55 dark violet / pad printing 30 x 7 mm



52 53 45 51



49 44 40

39 neutro / tampografia 60 x 7 mm
39 neutral / pad printing 60 x 7 mm

Soft

design innovativo dal morbido profilo
an innovative design and a soft profile



**Linearità e comfort
di scrittura.**

Linear design and a comfortable writing position.

Soft
informazioni
tecniche
*technical
information*



È possibile combinare particolari di colori diversi della stessa versione (o codice), oppure abbinare elementi di versioni differenti.

You can combine differently coloured parts from the same version (or code number), or elements from different versions.

- | | |
|-------------------|------------------|
| ● A cappuccio | ● A cap |
| ● B fusto / punta | ● B barrel / tip |
| ● C gomma | ● C rubber |

1/5

CARATTERISTICHE

- meccanismo a rotazione
- realizzata in plastica ABS, atossica e ad alta resistenza
- impugnatura in gomma termoplastica
- refill X-20, inchiostro blu e nero
- disponibile con superfici lucide o verniciate in colore alluminio

FEATURES

- twist-action
- made of non-toxic, highly resistant ABS plastic
- grip in thermoplastic rubber
- X-20 refill, blue and black ink
- available in glossy or aluminium colour painted finish

2/5

AREA STAMPABILE

- 1 tampografia 30 x 7 mm
- 2 tampografia 40 x 8 mm

PRINT AREA

- 1 pad printing 30 x 7 mm
- 2 pad printing 40 x 8 mm

3/5

FUSTO

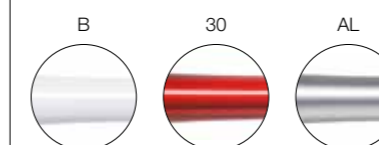

BARREL

4/5

PUNTA



TIP

5/5

COLORAZIONI

- trasparenti
- vernici metallizzate



COLOURS

- transparent
- metallic paintings

Soft S90 – B

colore bianco coprente con finitura lucida,
impugnatura in gomma termoplastica colorata
solid white colour with glossy finish, grip
in coloured thermoplastic rubber

51 viola / tampografia 40 x 8 mm
51 violet / pad printing 40 x 8 mm



39

52

53

45



55

49

44

40

Soft S90 – B 30

fusto colore bianco coprente con finitura lucida, cappuccio in colore trasparente
con finitura lucida, impugnatura in gomma termoplastica colorata
solid white colour barrel with glossy finish, transparent colour
cap with glossy finish, grip in coloured thermoplastic rubber

**La gomma garantisce
un effetto grip.**

Rubber for non-slip grip.

40 grigio + 52 giallo / tampografia 40 x 8 mm
40 grey + 52 yellow / pad printing 40 x 8 mm



39

52

53



51

55

49

44

40

45 rosso / tampografia 40 x 8 mm
45 red / pad printing 40 x 8 mm



Soft S90 – 30

colori trasparenti con finitura lucida,
impugnatura in gomma termoplastica colorata
transparent colours with glossy finish,
grip in coloured thermoplastic rubber

**Forma sinuosa che
non passa inosservata.**

*Sinuous shape that is sure
to catch attention.*



55 viola scuro / tampografia 30 x 7 mm
55 dark violet / pad printing 30 x 7 mm



Soft S90 – AL 30

fusto verniciato in colore alluminio, cappuccio in colori trasparenti
con finitura lucida, impugnatura in gomma termoplastica colorata
aluminium colour barrel, transparent colour cap
with glossy finish, grip in coloured thermoplastic rubber

40 grigio / tampografia 30 x 7 mm
40 grey / pad printing 30 x 7 mm



39 neutro / tampografia 40 x 8 mm
39 neutral / pad printing 40 x 8 mm



Polo

armonia di forme e di spazi
harmony of form and space



**Equilibrio di linee
decise e curve delicate.**

*A perfect balance of bold
styling and soft curves.*

Polo

informazioni tecniche

technical information

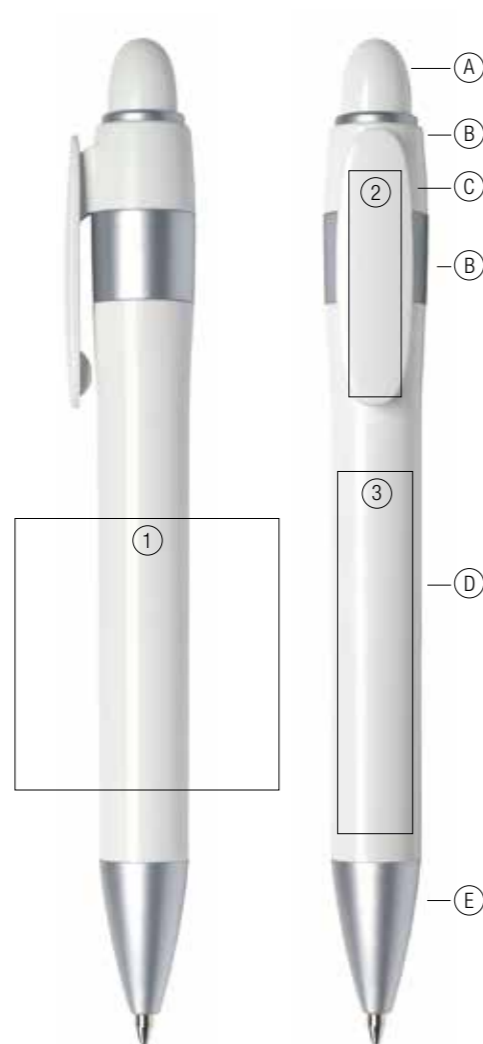

- | | |
|------------|---------------|
| Ⓐ tappino | Ⓐ push-button |
| Ⓑ raccordo | Ⓑ joint trim |
| Ⓒ clip | Ⓒ clip |
| Ⓓ fusto | Ⓓ barrel |
| Ⓔ punta | Ⓔ tip |

È possibile combinare particolari di colori diversi della stessa versione (o codice), oppure abbinare elementi di versioni differenti.

You can combine differently coloured parts from the same version (or code number), or elements from different versions.

1/5

CARATTERISTICHE

- meccanismo a scatto con molla di ritorno
- realizzata in plastica ABS, atossica e ad alta resistenza
- refill Jumbo, inchiostro blu e nero
- disponibile con superfici lucide

FEATURES

- retractable with return spring
- made of non-toxic, highly resistant ABS plastic
- Jumbo refill, blue and black ink
- available in glossy finish

2/5

AREA STAMPABILE

- 1 serigrafia 35 x 36 mm
- 2 tampografia 30 x 7 mm
- 3 tampografia 48 x 10 mm

PRINT AREA

- 1 screen printing 35 x 36 mm
- 2 pad printing 30 x 7 mm
- 3 pad printing 48 x 10 mm

3/5

FUSTO, CLIP E TAPPINO

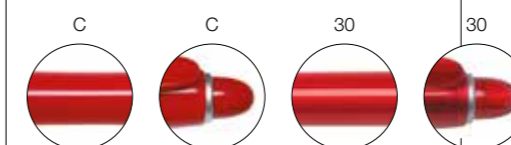

BARREL, CLIP AND PUSH-BUTTON

4/5

PUNTA E RACCORDO

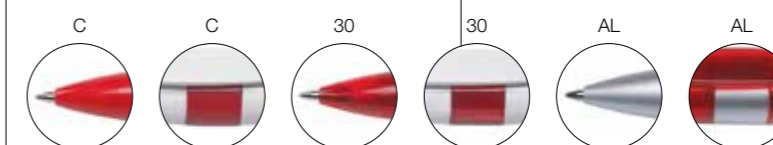

TIP AND JOINT TRIM

5/5

COLORAZIONI

- coprenti
- trasparenti

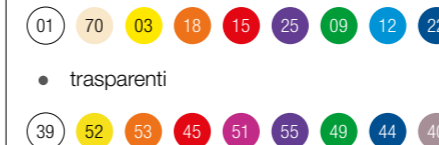

COLOURS

- solid
- transparent

Polo P600 – B

fusto, clip e tappino in colore bianco coprente,
particolari in colori coprenti, finiture lucide
solid white colour barrel, clip and push-button,
solid colours small parts, glossy finishes

**Il corpo perfettamente
cilindrico e la clip fissa,
consentono di stampare
in serigrafia a più colori.**

*The perfectly cylindrical body and fixed
clip facilitate multi-colour screen printing.*



12 azzurro / tampografia 48 x 10 mm
12 light blue / pad printing 48 x 10 mm



04 nero / tampografia 30 x 7 mm
04 black / pad printing 30 x 7 mm
—
tampografia 48 x 10 mm
pad printing 48 x 10 mm



22



Polo P600 – C

colori coprenti con finitura lucida
solid colours with glossy finish



01



70 crema / tampografia 30 x 7 mm
70 cream / pad printing 30 x 7 mm



03



18 arancio / tampografia 30 x 7 mm
18 orange / pad printing 30 x 7 mm



15



09



22



04

Polo P600 – C AL

colori coprenti con finitura lucida,
particolari verniciati in colore alluminio
solid colours with glossy finish, aluminium
painted finish small parts



03 giallo / tampografia 30 x 7 mm
03 yellow / pad printing 30 x 7 mm



01



18



15



22

04 nero / tampografia 48 x 10 mm
04 black / pad printing 48 x 10 mm



Polo P600 – 30 AL

colori trasparenti con finitura lucida,
particolari verniciati in colore alluminio
transparent colours with glossy finish,
aluminium painted finish small parts

**I numerosi particolari
che compongono la penna
permettono contrasti cromatici
che la impreziosiscono.**

*The pen's numerous component parts
lend themselves to **attractive colour contrasts.***

40 grigio / tampografia 30 x 7 mm
40 grey / pad printing 30 x 7 mm



39



52



53



45



51

55 viola scuro / tampografia 30 x 7 mm
55 dark violet / pad printing 30 x 7 mm



49



44



5 / 5

Servizi services
minikit fluo
fluo minikit

NEW

Scopri tutte le vibrazioni positive dei cinque nuovi colori fluo.

find out all the positive vibrations of the five new fluo colours.



Ogni Minikit Fluo contiene 5 penne assortite nel colore fluo indicato in copertina. Sono disponibili 5 varianti.

Each Fluo Minikit contains 5 assorted pens in the colour suggested on the cover. There are 5 possible variants.

GIALLO / YELLOW



ARANCIO / ORANGE



ROSSO CORALLO / CORAL RED



FUCSIA / FUCHSIA



VERDE / GREEN



MINIKIT FLUO

- 5 penne stampate dei modelli disponibili nei colori fluo
- dimensioni: 14,7 x 19 cm (formato chiuso)

FLUO MINIKIT

- 5 printed pens of the models available in fluo colours
- size: 14,7 x 19 cm (closed format)

supporti di vendita
sales support

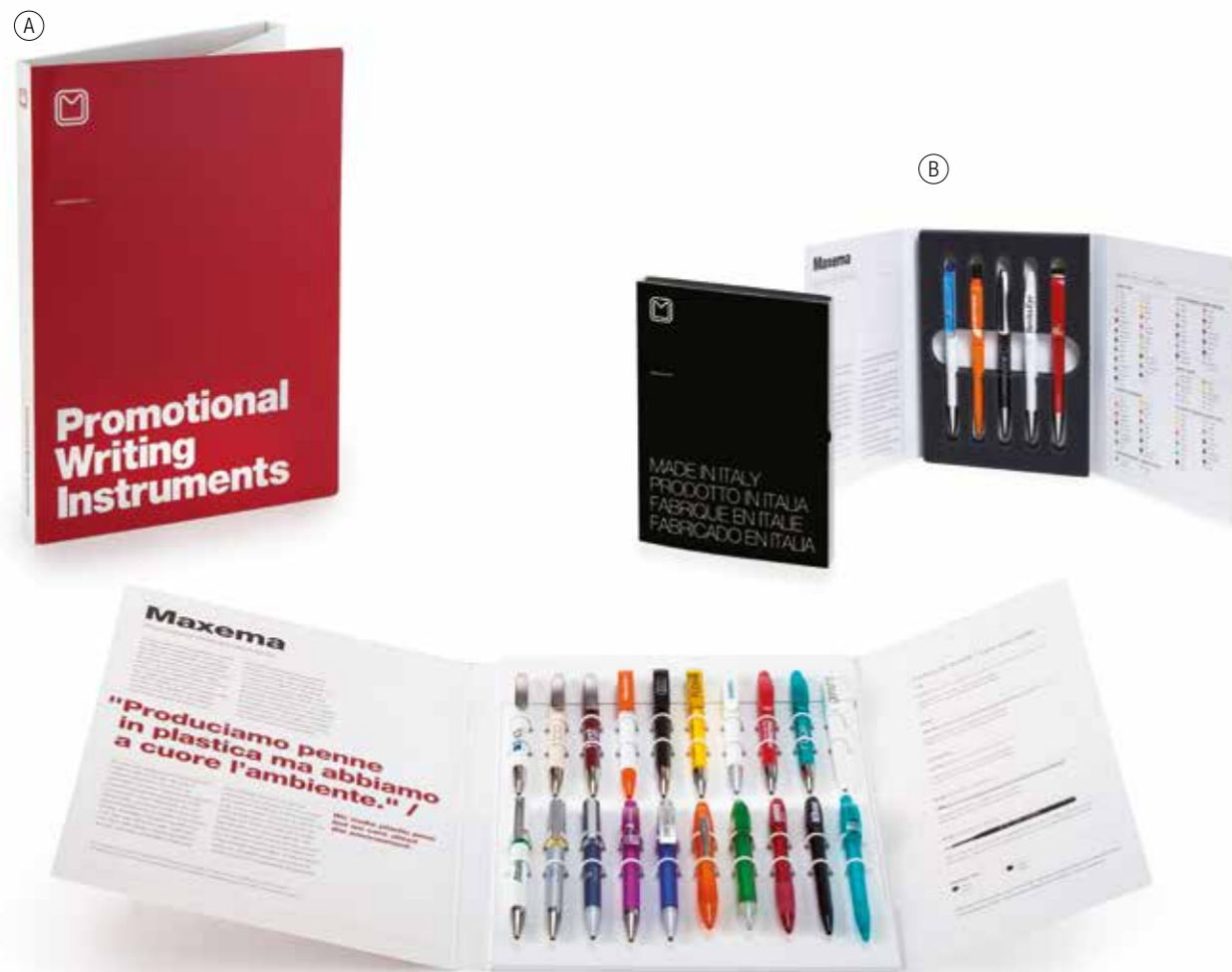

A

KIT GENERICO

- 20 penne stampate in colori assortiti dei modelli più rappresentativi
- dimensioni: 25 x 34 cm (formato chiuso)

GENERAL KIT

- 20 printed pens in assorted colours of the most representative models
- size: 25 x 34 cm (closed format)

B

MINIKIT

- 5 penne stampate in colori assortiti dei modelli più rappresentativi
- dimensioni: 14,7 x 19 cm (formato chiuso)

MINIKIT

- 5 printed pens in assorted colours of the most representative models
- size: 14,7 x 19 cm (closed format)

C



C

KIT MODELLO

- 20 penne stampate in colori assortiti di un unico modello
- dimensioni: 25 x 34 cm (formato chiuso)
- il KIT MODELLO è disponibile per: Flow Pure, Flow, Dot, Zink, View, Tag, Icon, Icon Green, Tag Green, Ethic, Pixel, Next.

MODEL KIT

- 20 printed pens in assorted colours of a single model
- size: 25 x 34 cm (closed format)
- the MODEL KIT is available for: Flow Pure, Flow, Dot, Zink, View, Tag, Icon, Icon Green, Tag Green, Ethic, Pixel, Next.

Su richiesta si possono realizzare campionari personalizzati con penne di specifiche versioni e colori.

On request we can prepare customised sets of samples containing specific versions and colours of pens.

D



1

2

3

D

RACCOLTORI

- i Kit sono disponibili in raccoglitori da 1, 2 o 3

1 28 x 33 x 3 cm

2 28 x 33 x 5,5 cm

3 28 x 33 x 8 cm

BOX SETS

- the Kits are available in 1, 2 or 3 unit box sets

1 28 x 33 x 3 cm

2 28 x 33 x 5,5 cm

3 28 x 33 x 8 cm

Servizi services

palette colori colour palette

coprenti / solid

01 bianco white	70 crema cream	03 giallo yellow	18 arancio orange	15 rosso red	74 bordeaux burgundy
60 rosa pink	61 magenta magenta	71 viola chiaro light violet	25 viola scuro dark violet	72 cuoio leather	73 marrone brown
79 lime lime	09 verde green	75 verde scuro dark green	26 acquamarina aquamarine	27 ottanio octan green	64 azzurro pastello pastel blue
77 ciano cyan	12 azzurro light blue	22 blu blue	05 grigio grey	04 nero black	

trasparenti / transparent

39 neutro neutral	52 giallo yellow	53 arancio orange	45 rosso red	59 rosa pink	41 magenta magenta
31 lilla lilac	51 viola violet	55 viola scuro dark violet	37 ambra amber	38 marrone brown	78 lime lime
49 verde green	47 acquamarina aquamarine	34 azzurro light blue	67 ciano cyan	44 blu blue	30 grigio chiaro light grey
40 grigio grey	50 grigio scuro dark grey				

Icon green e Tag green coprenti / solid Icon green and Tag green

01 bianco white	70 crema cream	42 giallo yellow	43 arancio orange	35 rosso red	13 marrone brown
29 verde green	65 verde scuro dark green	77 ciano cyan	54 blu blue	04 nero black	

vernici metallizzate / metallic paintings

91 perla pearl	92 oro gold	83 rame copper	85 rosso red	81 viola violet	82 viola scuro dark violet
89 verde green	94 avio aviation	95 blu blue	96 antracite anthracite	alluminio aluminium	

fluo coprenti / solid fluo

02 giallo yellow	17 arancio orange	14 rosso corallo coral red	56 fucsia fuchsia	08 verde green
------------------	-------------------	----------------------------	-------------------	----------------

fluo trasparenti / transparent fluo

20 giallo yellow	33 arancio orange	24 rosso corallo coral red	46 fucsia fuchsia	48 verde green
------------------	-------------------	----------------------------	-------------------	----------------

trattamento galvanico / galvanic process

● cromato chrome	● dorato gold
------------------	---------------

Servizi services

codici pantone pantone codes

In questa tabella sono riportati i nostri colori con i codici Pantone che più si avvicinano a quelli della nostra Palette. La corrispondenza è puramente indicativa.

Our colour chart is shown below with the Pantone codes closest to those of our Palette. Matches are approximate.

coprenti / solid

01 bianco	70 crema /cream	03 giallo /yellow	18 arancio / orange	15 rosso / red	74 bordeaux / burgundy
60 rosa / pink	61 magenta / magenta	71 viola chiaro / light violet	25 viola scuro / dark violet	72 cuoio / leather	73 marrone / brown
79 lime / lime	09 verde / green	75 verde scuro / dark green	26 acquamarina / aquamarine	27 ottanio / octan green	64 azzurro pastello / pastel blue
77 ciano / cyan	12 azzurro / light blue	22 blu / blue	05 grigio chiaro / light grey	04 nero / black	

pant 7499
pant 120
pant 1505
pant 187
pant 195
pant 1905
pant 213
pant 270
pant violet
pant 7571
pant 7582
pant 381
pant 348
pant 3435
pant 3262
pant 321
pant 283
pant 2995
pant 285
pant 287
pant cool gray 6
pant black 6

trasparenti / transparent

39 neutro / neutral	52 giallo / yellow	53 arancio / orange	45 rosso / red	59 rosa / pink	41 magenta
31 lilla / lilac	51 viola / violet	55 viola scuro / dark violet	37 ambra / amber	38 marrone / brown	78 lime / lime
49 verde / green	47 acquamarina / aquamarine	34 azzurro / light blue	67 ciano / cyan	44 blu / blue	30 grigio chiaro / light grey
40 grigio / grey	50 grigio scuro / dark grey				

pant 116
pant 1505
pant 200
pant 1905
pant 213
pant 2705
pant violet
pant 2425
pant 7571
pant 7582
pant 381
pant 348
pant 3272
pant 283
pant 306
pant 286
pant cool gray 6
pant 437
pant 446

Icon green e Tag green coprenti / solid Icon green and Tag green

01 bianco / white	70 crema /cream	42 giallo / yellow	43 arancio / orange	35 rosso /red	13 marrone / brown
29 verde / green	65 verde scuro / dark green	77 ciano / cyan	54 blu / blue	04 nero / black	

pant 7499
pant 012
pant 151
pant 179
pant 7532
pant 7741
pant 343
pant 2995
pant 7685
pant black 6

I colori Pantone sono disponibili su richiesta, contattateci per conoscere i quantitativi minimi per ogni modello.

Pantone colours are available on demand. Please contact us to find out the minimum order quantity for each model.

Servizi services

inchiostri e refill *inks and refills*

X-20



lunghezza 107 mm, fino a 2000 metri di scrittura
length 107 mm, for up to 2000 metres of writing

jumbo



lunghezza 107 mm, fino a 2500 metri di scrittura
length 107 mm, for up to 2500 metres of writing

RT 90 su richiesta / on demand



sfera in acciaio inox Ø 1 mm, lunghezza 98 mm, fino a 4000 metri di scrittura
ball stainless steel Ø 1 mm, length 98 mm, for up to 4000 metres of writing

RT 90 su richiesta / on demand



sfera in acciaio inox Ø 0,8 mm, lunghezza 98 mm, fino a 4000 metri di scrittura
ball stainless steel Ø 0,8 mm, length 98 mm, for up to 4000 metres of writing

inchiostri / inks



blu
blue

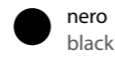

nero
black

Il tubetto del refill è in polipropilene, la punta è in ottone nichelato e la sfera in acciaio inox Ø 1 mm. L'inchiostro, atossico, è Dokumental.

The refill's barrel is made of polypropilene, the tip is made of nickel-plated brass and the ball stainless steel Ø 1 mm. The non-toxic ink is Dokumental.

Tutti gli inchiostri Dokumental sono conformi alla normativa europea REACH e americana TSCA.

All Dokumental inks comply with European REACH and American TSCA standards.

MADE IN ITALY

PRODOTTO IN ITALIA

FABRIQUE EN ITALIE

FABBRICADO EN ITALIA

